

LIONEL SIGNATURE EDITION

VOLUME ONE 2010



Table of Contents

INTRODUCTION	
Welcome from the CEO	3
A Guide to Product Features	4-5
Some Lionel Basics	5
VISION LINE	
Steam	6-13
Diesel	14-15
CLASSIC LINE	
Postwar Scale	16-19
Standard O Scale	20-55
Traditional O Gauge	56-96
LionMaster	56-59
Conventional Classics	70-79
ACCESSORIES	97-115
CONTROL SYSTEMS	116-121
TRACK	
FasTrack Track System	122-127
O-27 Track System	128-129
O Gauge Track System	130-131
K-LINE BY LIONEL	132-165
AMERICAN FLYER	166-181
LARGE SCALE TRACK	181
THE ELECTRIC RR CO.	182
LIONEL RAILROADER CLUB	INSIDE BACK COVER

The following Lionel marks are used throughout this catalog and are protected under law. All rights reserved.

Lionel®, LEGACY™, TrainMaster®, Odyssey®, RailSounds®, CrewTalk™, TowerCom™, DynaChuff™, StationSounds™, Pullmor®, ElectroCoupler™, Magne-Traction®, CAB-1® Remote Controller, American Flyer®, Lionel ZW®, ZW®, MagniVision®, TMCC®, Lionelville™, Wireless Tether™, Powerhouse™, LionMaster®, Conventional Classics™, Postwar Celebration Series™, TruRail™, PH-1 Powerhouse®, Powermaster®, Powerstation-Powerhouse®, Accessory Motor Controller™, AMC™, Accessory Switch Controller™, ASC™, Action Recorder

Controller™, ARC™, Track Power Controller 300™, TPC 300™, Track Power Controller 400™, TPC 400™, Block Power Controller™, BPC™, Operating Track Controller™, OTC™, FatBoy™, Lionel Lines®, Joshua Lionel Cowen Series™, Lionel Kiddie City®, Lionel Playworld®, Lockon®, TrainSounds™, MultiHorn™, MultiWhistle™, Choo-Choo™

TMs belonging to Union Pacific are All Rights Reserved

TMs belonging to Canadian Pacific are All Rights Reserved

TMs belonging to CSX are All Rights Reserved

Pittman® is a registered trademark of Pittman, a PennEngineering company

Any reproduction, transmission, or dissemination of the material here in is strictly prohibited.

Trademarks owned by Lionel L.L.C. are indicated throughout this document. Items depicted in this catalog are subject to change in price, color, size, design, and availability. Verify features on product package. Retail prices are suggested. See your Authorized Lionel Dealer for more information.



Dear Friends,

Anyone who's spent any time in the model train hobby knows the importance and pleasure of looking to the past. The legendary locomotives of American history have long been the inspiration for our most popular products. And nothing excites us more than being able to take these beloved items and give them an innovative, contemporary spin.

To start with, two of our most iconic locomotives will take their rightful place in Lionel's revolutionary and acclaimed VISION product line: the legendary 700E Scale Hudson and 4-6-6-4 Scale Challenger. We've taken these fan favorites and imbued them with state-of-the-art features and unparalleled detailing. Not only will these be spectacular to behold, but they'll be exceedingly fun to run! I can't wait until you see the new steam and sound features we have planned for both of them.

In our efforts to pay homage to the past, we're also producing three oft-requested Conventional Classics selections. The 1958 Virginian Rectifier set, the 1959 Santa Fe Alco Freight set, and the legendary Lionel Girls Train from 1957. Unlike the VISION selections, these sets will be offered in all their original glory, from the 1950s packaging to the original and authentic deco. (I guarantee you the colors will be exquisite!)

And finally, I'm pleased to be able to preview with you our updated ZW-L Transformer. The sleek, new design harkens back to Lionel's classic ZWs, but this iteration delivers all the modern day power and performance today's technology allows. Happily, you can look forward to installing this transformer on your layouts in 2010!

Advancing technology allows us the ability to enjoy our trains in a way that previous generations could only dream about. But it's always nice to look back. That's why, this year, we're proud to say everything old is new again!

Best wishes,

Jerry Calabrese

Jerry Calabrese
President and CEO
LIONEL ELECTRIC TRAINS



See page 120 for details!

LIONEL'S DETAILED GUIDE TO PRODUCT FEATURES

1. OPERATION

TRANSFORMER CONTROL

All Lionel locomotives—from the most sophisticated to the most basic—can be controlled by a standard transformer. Even older transformers can run our most advanced models

LEGACY CONTROL SYSTEM

This revolutionary control system allows you to run your LEGACY Control System-equipped locomotive just like a real engineer runs his trains. With its enhanced sounds and 200 speed steps, this system allows properly equipped engines to function with unparalleled options. The CAB-2 Remote Controller has an LCD screen display, vibration that simulates the effort of the locomotive, and other exciting operating features.

ODYSSEY II SPEED CONTROL

Slow speed and start-up operation are smooth and steady with ODYSSEY II Speed Control. Watch your locomotive as it creeps through the yard or fights up a grade without hesitation.



TRAINMASTER COMMAND CONTROL

Locomotives equipped with the classic TrainMaster Command Control system are controlled by commands from your CAB-1 or CAB-2 Remote Controller. ElectroCouplers, basic sounds, and multiple unit lash-ups are all at your fingertips as you walk around your layout.



ODYSSEY SYSTEM

Paired with classic TrainMaster Command Control, locomotives equipped with the Odyssey System maintain your speed up grades and around curves.



ELECTROCOUPLERS

(LEGACY OR TMCC required)

Open these couplers anywhere on the layout—without uncoupling track sections. The CAB-1 or CAB-2 Remote Controller activates the ElectroCouplers. Also, be sure to listen for authentic sounds of the coupler in operation with the RailSounds sound system.



WIRELESS TETHER CONNECTION

Looking to enhance the appearance of Lionel steam locomotives, we developed the exclusive infrared Wireless Tether connection so that the locomotive and tender can communicate without cumbersome wiring between the units. Lionel steamers are the only locomotives in O gauge offering this special feature.



MAGNE-TRACTION

On some classic or Postwar locomotives, the wheels are magnetized, increasing track adhesion for extra traction and stability around curves

TRACTION TIRES

One or more of the driving wheels are fitted with rubber tires for extra pulling power and stability for hauling long strings of cars. Traction tires grip the rails, enhancing tractive effort.

2. SOUND AND SMOKE

RAILSOUNDS

Widely regarded as the industry standard, the impressive RailSounds sound system brings the real sounds of the railroad to your layout. From the mechanical symphony of the locomotives, to the commotion of the station, you will be impressed by the digitally recorded samples of these special and authentic sounds.

LEGACY REAL-TIME QUILLING WHISTLE/QUILLING HORN

Push up and ring the warning bell control button one ring at a time with your own rhythm signature! Pull down on the lever and the horn/whistle responds with increasing intensity. Like a real engineer, you develop your own signature sound, “quilling” the steam whistle or changing the harmonics and intensity of the diesel horn.

BRAKING SOUNDS

Press the BRAKE button on your CAB-1 or CAB-2 Remote Controller, or rapidly decrease your throttle and listen for the screeching of your locomotive's brakes.

START-UP AND SHUT-DOWN

Listen as the diesel engine turns over or the steam locomotive comes to life. You will also hear the sounds of the giant locomotive gradually fade away when you turn off power.

STEAM LET-OFF/BLOW-OFF

(LEGACY or TMCC required)

At the press of a button, your steam locomotive will replicate the sound of hot steam being released from the cylinders.

DIESEL RPM

Throttle up your locomotive and listen as the locomotive's RPMs increase. While the RPM sounds automatically intensify with the speed of the engine and the power supplied to the track, you can also fine-tune the levels with your Remote Controller.

DYNACHUFF

A favorite feature among steam fans, DynaChuff is the varying intensity of the locomotive's chuffing, synchronized with the speed of the locomotive.

CREWTALK COMMUNICATION

(LEGACY or TMCC required)

This is radio communication inside your locomotive, caboose, and other cars. Operate several CrewTalk-equipped locomotives with CrewTalk-equipped rolling stock, and you will find that these messages are sequenced to sound as though personnel stationed at different parts of the train are radioing each other.

TOWERCOM ANNOUNCEMENTS

(LEGACY or TMCC required)

“1361, you're clear for departure.” Locomotives equipped with TowerCom feature a specialized announcement or announcements from the tower to your locomotive. Many TowerCom announcements include your locomotive's road name and number.

STATIONSOUNDS

With a StationSounds-equipped passenger car, you will hear the station's loudspeaker announce arrivals and departures. En route, the conductor makes dining reservations and station stop announcements.

SMOKE

Fan-driven smoke units provide a steady flow of smoke, and puffing smoke units create short blasts of smoke as the locomotive moves along the track. For the most realistic smoke effects, synchronized smoke units coordinate the blasts of smoke with the revolution of the drivers and the DynaChuff sounds of the locomotive.



At Lionel, we are proud to present the finest, most advanced locomotives—powerful models with tried-and-true performance and cutting-edge technology. Over the years, we have revolutionized this great hobby with advances in locomotive traction, train operation, and on-board sounds. Use this guide to learn about the incredible features of Lionel locomotives.

3. ILLUMINATION

DIRECTIONAL LIGHTING

Most Command Control diesel locomotives and steam locomotives feature directional lighting. Operate a Command Control equipped diesel in forward, and the headlight illuminates the mainline. In reverse, the headlight shuts off, and the rear headlight or the headlight of a second diesel in Command Control equipped steam locomotives, the headlight remains on in both forward and reverse operation. In reverse, the tender back-up light (if present) will shine.

CLASSIFICATION LIGHTS AND MARKER LIGHTS

Classification lights are located on the boiler front or top of some steam locomotives, while marker lights are on the rear of some steam locomotive tenders. These lights are also located on the ends of some diesel locomotives.

LIGHTED NUMBER BOARDS

Brightly illuminated, the locomotive's unique road number is displayed on the boiler top of some steam locomotives and on the ends of some diesel locomotives.

STROBE LIGHT

This flashing warning light is located on the cab roof of some diesel locomotives.

DITCH LIGHTS

These low-mounted lights serve as close-range secondary headlights on some diesel locomotives.

GROUND LIGHTS

These low mounted lights are located below the cab on the sides of some diesels. They face downward toward the ground to help drivers gauge diesel movement at slow speeds.

GLOWING FIREBOX AND FLICKERING FIREBOX

A red glow steadily emanates from the firehole inside of the cab of Lionel steam locomotives equipped with the glowing firebox. Steam locomotives equipped with a flickering firebox create the illusion of a live fire "flickering" within.

VARIABLE ASHPAN GLOW

Start up a Lionel steam locomotive equipped with this feature and look for a red glow on the outside of the locomotive between the ashpan and firebox. As speed increases, the light grows brighter, simulating the increased draft onto the fire.

LIONEL BASICS

GAUGE

On the real railroads as well as toy trains, gauge refers to the distance between the outside rails of the track. Lionel O gauge track systems—which include O, O-27, and FasTrack—all measure 1 1/4" between the outer rails. Any O gauge car or locomotive can ride on Lionel O gauge track, as long as the curve track used on your layout can accommodate your particular cars (see Minimum Curve section below).

Lionel G gauge track, which is wider than O gauge, supports G gauge cars and locomotives. Lionel S gauge track is narrower than O, and supports American Flyer and other S gauge cars.

SCALE

Scale measures the relationship between a model and the real thing. Most Lionel cars generally measure about 1:48 scale. This relationship is approximate for the Lionel Traditional line of cars and locomotives, which typically can run on layouts with tight curves (like O-27 or O-31). Lionel Standard O freight cars and engines, which are made to be as exact as possible to 1:48 scale, oftentimes require a wider minimum curve, such as O-36 or more.

MINIMUM CURVE

This measurement is very useful in purchasing track, locomotives, and rolling stock that are compatible with one another. For example, assemble O-72 curved track into a circle and you will have a 72" diameter layout. Assemble O-31 curved track into a circle, and you will have a layout 31" in diameter.

A locomotive with a Minimum Curve requirement of O-31 will run on a layout with O-72 curves, but a locomotive with a Minimum Curve requirement of O-72 will not run on a layout with O-31 curves. For more information on easy layout planning, see The Lionel Train Book found on page 94.

TRADITIONAL vs. STANDARD O

Lionel O gauge locomotives and rolling stock are divided into two basic categories—Traditional and Standard O. Both lines are O gauge and can be run together if Minimum Curve requirements allow. Generally, the difference is a matter of size and consistent proportions. Traditional locomotives are sized for Traditional Rolling Stock, and Standard O locomotives are sized for Standard O Rolling Stock. Some other distinguishing features of each category are listed below.

RECOMMENDED MINIMUM CURVE

Lionel locomotives and rolling stock are thoroughly tested to determine their Minimum Curve requirement. In some cases, a Lionel car or locomotive may be able to easily negotiate most, but not all, possible track configurations for that Minimum Curve. For these products, a Recommended Minimum Curve is also given. This larger measurement allows for all combinations of Lionel track and switches.

Curves	Diameter
A O72	72"
B O54	54"
C O36	36"
D O31	31"
E O27	27"

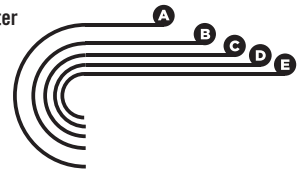

LIONEL TRADITIONAL

- Based on classic Lionel designs
- Approximate scale proportions
- Perfect additions to Lionel ready-to-run train sets
- Can run on any O gauge track curve, even O-27 (unless noted otherwise)

LIONEL STANDARD O

- Accurate reproductions of rolling stock and locomotives
- Scale proportions
- Super-detailed with many separately applied parts
- Check the Minimum Curve requirement for each car or locomotive



700E SCALE HUDSON

Lionel reintroduces the legendary 700E Scale Hudson—now with incomparable VISION features.

In 1937, Lionel unveiled what would become one of the most famous locomotives ever in model trains—the legendary 700E Scale Hudson. Based on the J1-e class of New York Central's world-famous Hudson engines, the Lionel prewar model aimed for 1/48th scale, rivet-for-rivet perfection. The ultimate statement piece in trains, this "aristocrat of models" instantly set the century-standard for engineering excellence and detailed realism that is as impressive today as it was over 70 years ago.

Our lofty goal today is the same as it was in the early days of Lionel—to create the most innovative, ground-breaking model trains in the world. To complete the circle of excellence begun in Lionel's earliest days, we proudly present the VISION 700E Scale Hudson, equipped with some of the most sophisticated and innovative features ever offered in model trains. As a VISION Line locomotive, the legendary Lionel scale J1-e has been re-engineered to give you the most authentic, technically advanced Hudson ever made, with unprecedented operational realism and user control. Equipped with the Lionel LEGACY Control System, a full array of lighting options, smoke and steam effects, and other features are synchronized to the unequaled, ultra-realistic RailSounds sound system.

Using much of the tooling that built the first 700E, Lionel offers the new scale J1-e in the original #5344 number. In addition, the VISION Scale Hudson is also available in a 763E-inspired gunmetal grey paint scheme.

Authentic Detailing!

- Prototypical swinging **BELL** synchronized to bell sounds
- Swing-out scale front coupler with interchangeable, fixed O-Gauge coupler for double-heading
- Opening roof vent
- Cab window glass
- Opening boiler front with authentic interior detail
- Separately applied details including grab irons, piping, and valves
- Spoked drivers with metal rims
- Realistic coal load in tender

Lighting Features!

- Enhanced realistic lighting in cab interior
- Directional lighting including operating locomotive headlight and tender back-up light
- Illuminated classification lights on the front of locomotive
- Flickering firebox in cab
- Variable ashpan glow

Steam and Smoke Features!

This engine comes equipped with **TruRail Steam** – a CAB-controlled, variable intensity steam and smoke effect. Here are some of the features operators can simulate:

- Realistic **WHISTLE STEAM** effects
- Operating smoke from stack
- Fan-driven smoke unit with adjustable smoke output delivers varying intensity of smoke to main stack and whistle.
- Most steam effects are synchronized to the RailSounds sound system.

Upgraded Sound Features!

- **LEGACY RailSounds** sounds system synchronizes realistic sounds to nearly all aspects of locomotive operation, features, and effects. This product also includes two state of the art FatBoy speakers for the ultimate in sound reproduction. Just look at how many ways you can enhance the sound experience:
- Control realistic sounds synchronized to TruRail Steam features including whistle steam.



- Independently adjustable volume control allows you to use the Remote Controller to lower the level of background effects (such as chuffing) while keeping operator-controlled effects (such as the whistle) at full volume
- Bell sounds are synchronized to actual movement of swinging bell
- **TruRail Dialog** – Activate upgraded dialog features which boast the most realistic dialogue scenes and authentic railroad terminology possible. Also, dialog scenes can change with engine operation and user control.
- Six official railroad speeds with CrewTalk dialogue

- **TruRail Signals** – Activate the “quilling” whistle and user playable bell featuring continuous or single strike sounds with variable intensity. There’s a dedicated CAB-2 control for both whistle and bell functions.
- **TruRail Laboring** – Control the variable laboring sounds with 32 levels of simulated dynamic load of the locomotive.
- **TruRail Chuff** – Experience prototypical four-chuffs per revolution chuffing sound synchronized with linkage and drive wheel position.

Other High-End Features

- **LEGACY Control System** equipped – You can run the in LEGACY Control mode, in TrainMaster Control mode, or in Conventional mode with a standard transformer
- **Odyssey II Speed Control** with On/Off switch
- High-torque motor with momentum flywheel
- **Wireless Tether** connection between locomotive and tender
- **ElectroCoupler** on rear of tender
- Die-cast metal locomotive body, pilot, and trucks

- Die-cast metal tender body and trucks
- Traction tires
- Engineer and fireman figures
- Minimum Curve: 0-42
- Length: 24 3/4”

6-11209 VISION 700E #5344 \$1599.99

Also Available:

6-11218 VISION HUDSON (GUNMETAL GREY) #5331 \$1599.99



UPGRADED
REALISTIC
LIGHTING

SWINGING
BELL

ALL ITEMS
NEW

VISION LINE CHALLENGERS

During World War II, as the Pacific front intensified, rail traffic congestion threatened to cripple western railroads like the Union Pacific. Railroads placed urgent requests for more motive power to the War Production Board. The UP knew of no better candidate for a fast freight hauler than the 4-6-6-4 simple articulated Challenger-type that they had developed with the American Locomotive Company in the 1930s.

These earliest Challengers, some 60 in total, proved their worth on the steep grades of the Wasatch Mountains, showing clearly that the big brute 4-6-6-4 engines had more power and speed than their predecessors.

In 1943, twenty five additional ALCO Challengers arrived at the Union Pacific Railroad. These locomotives were initially designed as coal burners thanks to plentiful Wyoming coal-fields. In 1944, however, some "Greyhound" Challengers of U.P. were converted to burn oil for Los Angeles passenger service, where they often exceeded 80 miles per hour speeds. The U.P. Challengers hauled passenger and freight consists through the late 1950s.

Five VISION Challengers are available for 2010, all equipped with the highest level of realistic features and state-of-the-art LEGACY technology that's possible. You'll see and feel the difference with features like injector and turbine steam effects, realistic Dual Sound effects, removable smoke deflectors, accurate smokestacks and tender types, and the best in high-tech realism.

Authentic Detailing!

- Swing-out scale front coupler with interchangeable, fixed O-Gauge coupler for double-heading
- Opening cab windows and roof vent
- Cab curtains and window glass

- Detailed and decorated cab interior
- Hinged cab deck
- Opening boiler front with authentic interior detail
- Authentic see-through boiler walkway
- Separately applied details including grab irons, piping, and valves
- Authentic smokestack interior detailing
- Prototypical dual smokestack
- Removable smoke deflectors – run your engine with or without "elephant ears"
- Opening roof hatches on tender
- Oil tender on U.P. Greyhounds
- Coal tender on black U.P. engines

Lighting Features!

- Enhanced realistic lighting in cab interior
- Directional lighting including operating locomotive headlight and tender back-up light
- Illuminated classification lights on the front of locomotive
- Illuminated rear marker lights on tender
- Illuminated number boards
- Flickering firebox in cab
- Variable ashpan glow
- Four illuminated work lights under boiler with On/Off switch

Steam and Smoke Features!

This engine comes equipped with **TruRail Steam** – a CAB-controlled, variable intensity steam and smoke effect. Here are some of the features operators can simulate:

- Accurate **WHISTLE STEAM** effects
- New realistic **DYNAMO STEAM** effects
- Fan-driven smoke unit with adjustable smoke output delivers varying intensity of smoke to main stack, whistle, and dynamo.
- Most steam effects are synchronized to the RailSounds sound system and are user controllable.

Upgraded Sound Features!

LEGACY RailSounds sounds system synchronizes realistic sounds to nearly all aspects of locomotive operation, features, and effects. This product also includes three speakers, two in the tender and one in the locomotive for the ultimate in sound reproduction. Just look at how many ways you can enhance the sound experience:

- Control realistic sounds synchronized to TruRail Steam features including blowdown, whistle steam, turbine steam, and injector steam.
- Independently adjustable volume control allows you to use the Remote Controller to lower the level of background effects (such as chuffing) while keeping operator-controlled effects (such as the whistle) at full volume.

A





C



- DUAL SOUND** – With a sound system equipped in your locomotive as well as the tender, Dual Sound enhances sound realism and localizes a wide variety of authentic sound effects.
- **TruRail Dialog** – Activate upgraded dialog features which boast the most realistic dialogue scenes and authentic railroad terminology possible. Also, dialog scenes can change with engine operation and user control.
 - Six official railroad speeds with CrewTalk dialogue
 - **TruRail Signals** – Activate the “quilling” whistle and user playable bell featuring continuous or single strike sounds with variable intensity. There’s a dedicated CAB-2 control for both whistle and bell functions.
 - **TruRail Laboring** – Control the variable laboring sounds with 32 levels of simulated dynamic load of the locomotive.
 - **TruRail Articulated Chuffs** – Prototypical four-chuffs per drive wheel revolution for each engine, with the phase relation between the two engines slipping as operating conditions vary, or under user control.
- Other high-end features**
- **LEGACY Control System** equipped – You can run the in LEGACY Control mode, in TrainMaster Control mode, or in Conventional mode with a standard transformer

- **Odyssey II Speed Control** with On/Off switch
- High-torque motor with momentum flywheel
- **Wireless Tether** connection between locomotive and tender
- **ElectroCoupler** on rear of tender
- Die-cast metal locomotive body, pilot, and trucks
- Die-cast metal tender body and trucks
- Traction tires
- All twelve driving wheels powered
- Accurate separately-applied builders plates
- Engineer and fireman figures
- Minimum Curve: 0-72
- Length: 32”

- A. 6-11210 Union Pacific #3967 (Black/white, coal fired) **\$1,824.99**
- 6-11220 Union Pacific #3989 (Black/white, coal fired) **\$1,824.99**
- B. 6-11211 Union Pacific #3976 (Grey/yellow, oil fired) **\$1,824.99**
- 6-11221 Union Pacific #3983 (Grey/yellow, oil fired) **\$1,824.99**

C. UNION PACIFIC CA-3 CABOOSE

First delivered in 1942, CA-3 class cabooses were the first steel-type caboose to enter the Union Pacific fleet. They were the only U.P. class to be built with a distinctive running board on the cupola roof, and they also came equipped with grab handles placed vertically along the cupola ends. Close to 200 CA-3 cabooses were built for the Union Pacific in the 1940s, all painted in standard freight car red early in their career.

- Die-cast metal sprung Q-type trucks
 - Hidden uncoupling tabs
 - Separately applied metal underframe details
 - Running boards on body roof and cupola roof
 - Smoke with On/Off switch
 - Detailed and decorated interior with figures
 - Interior illumination
 - Minimum Curve: 0-31
 - Length: 10”
- 6-27633 \$94.99**



Removable smoke deflectors

B



CLINCHFIELD CHALLENGER #663

While a large number of Challengers found service out West, 4-6-6-4s had colorful careers in the East, too. In 1942, eight Challengers were initially ordered by Clinchfield, and after the war they received four additional units. The Clinchfield Railroad also purchased six final Challenger locomotives in 1947 that the D&RGW had rejected a few years earlier and sent back to the War Production Board. On the Clinchfield, the single stack ALCO-built Challengers were used to haul Appalachian coal until dieselization forced them to the scrap yard in the early 1950s.

Equipped with the best of LEGACY Control System, the Clinchfield Challenger includes such features as Dynamo steam effects, Odyssey II Speed Control, and LEGACY RailSounds with realistic Dual Sounds. This engine also comes with a coal-type tender, accurate single smokestack,

and even includes smoke deflectors that can be attached and removed easily to give your Clinchfield Challenger a dramatic, new appearance.

Authentic Detailing!

- Swing-out scale front coupler with interchangeable, fixed 0-Gauge coupler for double-heading
- Opening cab windows and roof vent
- Cab curtains and window glass
- Detailed and decorated cab interior
- Hinged cab deck
- Opening boiler front with authentic interior detail
- Authentic see-through boiler walkway
- Separately applied details including grab irons, piping, and valves
- Authentic smokestack interior detailing
- Prototypical single smokestack

- Removable smoke deflectors – run your engine with or without “elephant ears”
- Opening roof hatches on tender
- Coal tender

Lighting Features!

- Enhanced realistic lighting in cab interior
- Directional lighting including operating locomotive headlight and tender back-up light
- Illuminated classification lights on the front of locomotive
- Illuminated rear marker lights on tender
- Illuminated number boards
- Flickering firebox in cab
- Variable ashpan glow
- Four illuminated work lights under boiler with On/Off switch

ALL ITEMS
NEW

REMOVABLE
SMOKE
DEFLECTORS

PROTOTYPICAL
SINGLE SMOKE
STACK

DYNAMO
STEAM
EFFECTS



Steam and Smoke Features!

- This engine comes equipped with TruRail Steam — a CAB-controlled, variable intensity steam and smoke effect. Here are some of the features operators can simulate:
- Accurate **WHISTLE STEAM** effects
- New realistic **DYNAMO STEAM** effects
- Fan-driven smoke unit with adjustable smoke output delivers varying intensity of smoke to main stack, whistle, and dynamo.
- Most steam effects are synchronized to the RailSounds sound system and are user controllable.

Upgraded Sound Features!

- **LEGACY RailSounds** sounds system synchronizes realistic sounds to nearly all aspects of locomotive operation, features, and effects. This product also includes three speakers, two in the tender and one state of the art FatBoy speaker in the locomotive for the ultimate in sound reproduction. Just look at how many ways you can enhance the sound experience:
- Control realistic sounds synchronized to TruRail Steam features including blowdown, whistle steam, turbine steam, and injector steam.
- Independently adjustable volume control allows you to use the Remote Controller to lower the level of background effects (such as chuffing) while keeping operator-controlled effects (such as the whistle) at full volume.
- **DUAL SOUND** — With a sound system equipped in your locomotive as well as the tender, Dual Sound enhances sound realism and localizes a wide variety of authentic sound effects.
- **TruRail Dialog** — Activate upgraded dialog features which boast the most realistic dialogue scenes and authentic railroad terminology possible. Also, dialog scenes can change with engine operation and user control.

- Six official railroad speeds with CrewTalk dialogue
- **TruRail Signals** — Activate the “quilling” whistle and user playable bell featuring continuous or single strike sounds with variable intensity. There’s a dedicated CAB-2 control for both whistle and bell functions.
- **TruRail Laboring** — Control the variable laboring sounds with 32 levels of simulated dynamic load of the locomotive.
- **TruRail Articulated Chuffs** — Prototypical four-chuffs per drive wheel revolution for each engine, with the phase relation between the two engines slipping as operating conditions vary, or under user control.

Other high-end features

- **LEGACY Control System** equipped — You can run the in LEGACY Control mode, in TrainMaster Control mode, or in Conventional mode with a standard transformer
- **Odyssey II Speed Control** with On/Off switch
- High-torque motor with momentum flywheel
- **Wireless Tether** connection between locomotive and tender

- **ElectroCoupler** on rear of tender
- Die-cast metal locomotive body, pilot, and trucks
- Die-cast metal tender body and trucks
- Traction tires
- All twelve driving wheels powered
- Accurate separately-applied builders plates
- Engineer and fireman figures
- Minimum Curve: 0-72
- Length: 32”

A. 6-11219 Clinchfield Challenger with Coal Tender **\$1,824.99**

B. CLINCHFIELD NORTHEASTERN CABOOSE

- Die-cast metal trucks and operating couplers
- Hidden uncoupling tabs
- Separately applied metal underframe details
- Smoke unit with On/Off control
- Train crew figure
- Interior illumination
- Detailed and painted interior
- Opening doors
- Minimum Curve: 0-31
- Length: 8 ½”

6-27640 **\$89.99**



B

SANTA FE 2-10-10-2 3000 STEAM LOCOMOTIVE

In 1911, Santa Fe 2-10-2's were combined with Baldwin-built front boiler sections to create ten mammoth 2-10-10-2 articulated mallet locomotives. At that time, these were the largest locomotives in the world – over 120 feet in length with tender, and weighing nearly a million pounds.



Besides its enormous size, one of the most arresting features of the 2-10-10-2 was the sleek “turtleback” tender that serviced the loco. With rounded sides and rear, and an overall modern appearance, turtleback tenders had a clean, streamlined look that was years ahead of its time. Most eye-catching was the distinctive cow-catcher fitted on the rear of the tender.

With this locomotive, Atchison, Topeka, and Santa Fe Railway discovered the limits of the compound mallet locomotive experiment. While their tractive effort was phenomenal, the engines suffered in overall speed. Simply put, the under-designed boiler and firebox could not make steam fast enough to power the massive cylinders at higher speeds. Ultimately, 3000-class mallets were relegated mainly to helper service in California on the Cajon Pass and on the Tehachapi Loop. By 1918, all ten “magnificent failures” were converted back to 2-10-2 locomotives. The unique turtleback tenders, however, lived on throughout the steam era to service a large assortment of Santa Fe engines.

WHAT MAKES THIS A VISION OFFERING?

For starters, like all top-of-the-line Lionel locomotives, it comes fully equipped with the LEGACY Control System, Odyssey II Speed Control, and LEGACY RailSounds; it has all the hi-tech realism you expect from Lionel. But that's only the beginning.

Unparalleled VISION Detailing and Lighting Features!

Our 2-10-10-2 takes model train realism to new heights with unprecedented body detailing, interior cab realism, and numerous separately applied parts.

- Upgraded realistic coupling and hose details between locomotive and tender

- Prototypical swinging **BELL** synchronized to bell sounds
- Swing-out scale front coupler with interchangeable 0 gauge coupler for double-heading
- Opening roof hatch on cab
- Decorated cab interior with enhanced panel detail
- Cab window glass
- Enhanced realistic lighting in cab interior
- Directional lighting including operating headlight and back-up light
- Illuminated front classification lights on locomotive
- Illuminated rear marker lights on tender
- Illuminated number boards
- Flickering firebox in cab
- Variable ashpun glow

New Steam and Smoke Features!

Lionel introduces **TruRail Steam** – a new CAB-controlled, variable intensity steam and smoke effect. See all the features operators can simulate:

- Dramatic and realistic **BLOW-DOWN** effects
- New and accurate **WHISTLE STEAM** effects
- Fan-driven smoke unit with adjustable smoke output delivers varying intensity of smoke to main stack, blow-down valve, and whistle
- All steam effects are synchronized to the RailSounds sound system and are user controllable

Upgraded Sound Features!

LEGACY RailSounds sound system synchronizes realistic sounds to nearly all aspects of locomotive operation, features, and effects. This product also includes two state-of-the-art FatBoy speakers for the ultimate in sound reproduction. Just look at how many ways you can enhance the sound experience:

- Control realistic sounds synchronized to **TruRail Steam** features including blowdown and whistle steam effects
- Independently adjustable volume control allows you to use the Remote Controller to lower the level of background effects (such as chuffing) while keeping operator controlled effects (such as the whistle) at full volume
- Bell sounds are synchronized to actual movement of swinging bell
- **TruRail Dialog** – Activate our upgraded dialog features which boasts the most realistic dialogue scenes and authentic railroad terminology possible. Also, dialog scenes can change with engine operation and user control
- Six official railroad speeds with CrewTalk dialog
- **TruRail Signals** – Activate the “quilling” whistle and user playable bell featuring continuous or single strike sounds with variable intensity. There's a dedicated CAB-2 control for both whistle and bell functions.
- **TruRail Laboring** – Control the variable laboring sounds with 32 levels of simulated dynamic load of the locomotive.
- **TruRail Articulated Chuffs** – Prototypical four-chuffs per drive wheel revolution for each engine, with the phase relation between the two engines slipping as operating conditions vary, or under user control.

Plus all the high-end features you've come to expect from Lionel

- **LEGACY Control System** equipped – You can run the engine in LEGACY Control mode, in TrainMaster Command Control mode, or in Conventional mode with a standard transformer
- **Odyssey II Speed Control** with ON/OFF switch
- High-torque motor with momentum flywheel
- **Wireless Tether** connection between locomotive and tender

PROTOTYPICAL
SWINGING BELL

WHISTLE
STEAM
EFFECT

FIRST TIME EVER
IN O-GAUGE



- **ElectroCoupler** on rear of tender
- Die-cast metal locomotive body, frame, and trucks
- Die-cast metal tender body and trucks
- Traction tires
- Accurate separately-applied builder's plates
- Engineer and fireman figures
- Minimum Curve: 0-72
- Length: Approx. 31"

6-11155 \$2,249.99

Go to www.lionel.com for more information on the Lionel VISION Line, and to learn about the features and benefits of Lionel's VISION LINE REWARDS Membership Club.



Never-before-seen blow-down effect! Incredible new steam whistle effect! Sensational sound feature!



Prototypical "Turtleback" tender with original cow-catcher fitted on the back end
Concept model shown

CANADIAN PACIFIC HYBRID

The future of railroading in dramatic Canadian Pacific livery



CANADIAN PACIFIC EVOLUTION HYBRID

After years of research and development, Evolution[®] Series locomotives by General Electric recently hit the rail, and they've quickly proved to be the most technologically advanced, fuel-efficient, and environmentally friendly diesel locomotives in history. A leader in modern railroading, Canadian Pacific has a full fleet of ES44AC Evolution engines in their line, 200 in total. Their reliance on these modern engines reflects the railroad's commitment to improving fuel efficiency and strict adherence to current environmental standards that minimize pollution.

The EcomaginationSM team of GE is already at work designing for the future, taking the success of their eco-friendly ES44 series of locomotives to the next level. Witness GE's Evolution Hybrid Locomotive – the most efficient and clean-running, high-horse power locomotive in existence. Soon, testing of the original Hybrid prototype will be complete, and this most modern of all engines will be ready for work on the modern railroad lines.

Bringing the future to you today, Lionel offers a special version of the Evolution Hybrid decorated in the dramatic red livery of Canadian Pacific. Very similar to the railroad's non-Hybrid version of this locomotive, the Canadian Pacific

Evolution Hybrid comes equipped with the same incredible features and details of Lionel's original GE's Evolution Hybrid. In particular, you'll get the ultra-modern and eco-friendly battery boxes along the side of the engine. The Hybrid also comes equipped with dramatic "charging lights" that flash in motion along the sides near the walkway deck.

With LEGACY Command Control, you have complete control over a multitude of features on this state-of-the-art engine. Uncompromising in the highest detail, accurate features, and realistic operation, the die-cast metal Canadian Pacific Evolution Hybrid is painstakingly designed to give you the ultimate experience in model railroading.





NEW

**DIE-CAST
METAL
BODY**

**CHARGING
LIGHTS**

**BATTERY
BOXES**

Spectacular Lighting Features!

- Prototypical battery "charging lights" flash in motion along sides of locomotive
- Enhanced realistic lighting in cab interior
- Directional lighting including dual LED headlights on front and rear
- Oscillating ditch lights on front
- Illuminated number boards
- Ground lights on sides

Unparalleled Detailing!

The die-cast metal Evolution Hybrid has an unprecedented level of body detailing and accurate, separately applied parts. Just look at all the special features:

- Opening compartment doors reveal hidden details
- Operating radiator fans
- Decorated cab interior with enhanced panel detail
- Die-cast metal body
- Die-cast metal trucks, pilot, and fuel tank
- Metal frame

Enhanced Sound Features!

LEGACY RailSounds sound system synchronizes realistic sounds to nearly all aspects of locomotive operation, features, and effects. Just look at how many ways you can enhance the sound experience:

- Independently adjustable volume control allows you to use the Remote Controller to lower the level of background effects (such as RPM levels) while keeping operator controlled effects (such as the horn) at full volume.
- Six official railroad speeds with CrewTalk dialog
- Eight diesel RPM levels
- **TruRail Dialog** – Activate our upgraded dialog features, which boast realistic dialog scenes and the most authentic railroad terminology possible. Also, dialog scenes can change with engine operation and user control
- **TruRail Signals** – Activate the "quilling" horn and user-playable bell featuring continuous or single strike sounds with variable intensity. There's a dedicated CAB-2 control for both horn and bell functions.

Plus all the high-end features you've come to expect from Lionel:

- **LEGACY Control System** – You can run the engine in LEGACY Control mode, in TrainMaster Command Control mode, or in Conventional mode with a standard transformer
- **Odyssey II Speed Control** with On/Off switch
- Two high-torque motors with momentum flywheel
- Front and rear **ElectroCouplers**
- Traction tires
- Fan-driven smoke unit
- Adjustable smoke output
- Minimum Curve: 0-42
- Recommended Curve: 0-54
- Length: Approx. 19"

6-28320 \$874.99

General Electric, GE and Evolution are registered trademarks and Ecomagination is a registered service mark of the General Electric Company

ANNOUNCING... POSTWAR SCALE LOCOMOTIVES AND ROLLING STOCK

Lionel's most famous postwar paint schemes on full scale Standard O locomotives and cars

Lionel is proud to offer for the very first time a brand new line of postwar Lionel engines and freight cars. It's the Postwar Scale line, where you'll find some of Lionel's most famous Postwar paint schemes applied to our modern pallet of highly detailed, 1:48th Scale Standard O locomotives and cars. Times have changed dramatically since the 1940s, and so has model railroading. O Gauge demand for proper scale, accurate detail, and state-of-the-art operating realism is as strong today as for the more traditional and conventional O-27 and O gauge classics of the past.

Now you can have some of the most memorable Lionel paint schemes on the most highly detailed, scale-sized engines and cars available. Each Postwar Scale piece is decorated true to the spirit of the postwar original in color and decoration, although scale upgrades to the deco (such as unique road numbers on A-A locomotive sets) are sometimes applied to upgrade realism. All Postwar Scale powered engines are equipped with Lionel's most advanced features, including LEGACY Command Control, LEGACY RailSounds, and Odyssey II speed control. Now can have the best of both worlds with Lionel's new series of Postwar Scale locomotives and cars!

POSTWAR SCALE F3 DIESELS

In 1947 General Motors first unveiled the streamlined F3 diesel locomotive. Just one year later, Lionel introduced its own version of this famous engine, the first diesel Lionel ever gambled to manufacture. One of the company's most memorable and best-selling locomotives ever, the Lionel F3 remained in the line until 1966.

Lionel proudly welcomes two of the rarest postwar F3 roadnames to the new Postwar Scale line –Milwaukee Road and Canadian Pacific. Manufactured for one year only, these have become two of the most sought after postwar F3s ever. To complete your scale diesel sets and provide more pulling power, Lionel also offers an additional separate-sale powered unit for each railroad.



Canadian Pacific F3 A-A set Includes

One powered A-unit and one non-powered A-unit

Milwaukee Road F3 A-B set Includes

One powered A-unit and one non-powered B-unit

All A and B Units on Pages 16-17 Feature

- Fan-driven smoke unit
- Adjustable smoke output in LEGACY Control or TMCC mode
- Directional lighting
- **ElectroCoupler** (front on all A-units, rear on B-unit)
- Die-cast metal trucks, pilot, and fuel tank
- Die-cast metal frame
- Separately applied metal details
- Traction tires
- Cab window glass

All Powered A Units Also Feature

- **LEGACY Control System** equipped – able to run in LEGACY Control mode, in TrainMaster Command Control mode, or in Conventional mode with a standard transformer
- **Odyssey II Speed Control** with On/Off switch
- **LEGACY RailSounds** sound system featuring:
 - CrewTalk dialog and TowerCom announcements, each with different scenarios depending on whether the locomotive is in motion or stopped
 - Six official railroad speeds with CrewTalk dialog
 - Eight diesel RPM levels
 - LEGACY “Real-Time Quilling Horn” control with instant quilling and correctly timed warning signals
 - Single hit or continuous mechanical bell sounds
- Dual powerful maintenance-free motors with momentum flywheels
- Refined Conventional Transformer Control mode with lower starting speeds

- Traction tires
- Illuminated number boards
- Operating marker lights
- Illuminated cab interior
- Engineer and fireman figures

Non-powered A Unit in Canadian Pacific A-A Also Features

- LED headlights
- Illuminated cab interior
- Illuminated number boards
- Operating marker lights
- Minimum Curve: 0-31
- Length: 13” each unit

- A. 6-34586 Milwaukee Road F3 A-B \$679.99**
- B. 6-34589 Milwaukee Road F3 Powered A-unit \$424.99**
- C. 6-34582 Canadian Pacific F3 A-A \$699.99**
- D. 6-34585 Canadian Pacific F3 Powered B-unit \$379.99**



**ALL ITEMS
NEW**

POSTWAR SCALE VIRGINIAN #2331

A. POSTWAR SCALE VIRGINIAN FM TRAINMASTER #2331

First produced in 1954, the classic Lionel FM TrainMaster was released only one year after the real Fairbanks Morse engines initially hit the rails. Lionel followed its first release of the Lackawanna FM with Virginian #2331, a handsome yellow scheme that was striped in either blue or black. For the Postwar Scale line, Lionel recreates the scarce blue and yellow version of #2331 on its top-of-the-line, scale TrainMaster fully equipped with the LEGACY Control System. There's also a matching scale Virginian caboose inspired by #6427 to run in your Postwar Scale consist.

- **LEGACY Control System** equipped –able to run in LEGACY Control mode, in Command Control mode, or in Conventional mode with a standard transformer
- **Odyssey II Speed Control** with On/Off switch
- **LEGACY RailSounds** sound system featuring:
 - CrewTalk dialog and TowerCom announcements, each with different scenarios depending on whether the locomotive is in motion or stopped
 - Six official railroad speeds with CrewTalk dialog
 - Eight diesel RPM levels
 - LEGACY "Real-Time Quilling Horn" control with instant response for realistic signature "quilling" and correctly timed warning signals
 - Single hit or continuous mechanical bell sounds
- Dual, powerful maintenance-free motors with momentum flywheels
- **Magne-Traction** track gripping system
- Fan-driven smoke unit with adjustable smoke output
- Front and rear **ElectroCouplers**
- Directional lighting, including LED headlights
- Operating radiator fans
- Separately applied metal vent screens and handrails
- Die-cast metal pilots, fuel tanks, and trucks
- Metal frame
- Accurate, separately applied builder's plates
- Illuminated number boards
- Illuminated cab interior
- Engineer and fireman figures
- Minimum Curve: 0-31
- Length: 16 1/2"

6-34581 \$494.99

B. POSTWAR SCALE STOCK CAR 2-PACK

2-Pack Includes

- 6-17722 #6356 New York Central Stock Car
- 6-17723 #6556 M-K-T Stock Car

Features

- Die-cast metal sprung trucks and operating couplers
- Hidden uncoupling tabs
- Die-cast metal frame
- Metal underframe details
- Opening doors
- Four hand-painted cattle figures included
- Each car individually boxed
- Minimum Curve: 0-31
- Length: 11 1/2"

6-17721 \$139.99

C. POSTWAR SCALE 6464 BOXCAR 2-PACK

2-Pack Includes

- 6-27284 #6464-1 Western Pacific Boxcar
- 6-27285 #6464-25 Great Northern Boxcar

Features

- Die-cast metal sprung trucks with operating couplers
- Separately applied metal underframe details
- Opening doors
- Box loads in interior
- Each car individually boxed
- Minimum Curve: 0-31
- Length: 11 1/4"

6-27283 \$139.99

D. POSTWAR SCALE #6427 VIRGINIAN CABOOSE

- Die-cast metal trucks and operating couplers
- Hidden uncoupling tabs
- Separately applied metal underframe details
- Smoke unit with On/Off control
- Train crew figure
- Interior illumination
- Detailed and painted interior
- Opening doors
- Minimum Curve: 0-31
- Length: 8 1/2"

6-27642 \$89.99



2-PACK



D



2-PACK



B

ALL ITEMS
NEW



D

NEW YORK CITY TRANSIT AUTHORITY R16 SUBWAY SET

R16 Class scale subway cars are now available by Lionel in the well-recognized silver and blue paint scheme. Beginning around 1970 MTA began the transition to this new and vibrant color scheme, a repainting operation which lasted into the mid-1970s.

In 1954, the very first R16 subway car was put on special display at a commemoration of the IRT's 50th anniversary. 200 total steel cars were soon to follow, most of which were assigned initially to the BMT Eastern Division. Unique in design, the R16 Class subway cars were fitted with distinctive circular end windows, an interesting feature originally seen on R15 IRT cars and retrofitted onto R11s. Later in their career, R16s were moved to a wide variety of other lines, and they serviced New York City's subways faithfully until the replacement of the cars was complete in 1986. Today, one R16 subway car is preserved at the New York Transit Museum.

Featuring the LEGACY Control System, Lionel R16 subway cars have opening doors and authentic subway sounds. Listen for the operator announcing true-to-life stops along the route. They also feature a wealth of realistic detail, decoration, and lighting features both inside the cars and out. Add the additional two-pack to the powered R16 set to complete this scale subway package.

Set Includes

One powered unit and three non-powered subway cars

All Cars Feature

- **LEGACY Control System** equipped – able to run in LEGACY Control mode, in Command Control mode, or in Conventional mode with standard transformer
- **LEGACY RailSounds** sound system featuring:
 - CrewTalk dialog and TowerCom announcements
 - Sounds and effects digitally recorded from actual subway
 - LEGACY "Real-Time Quilling Horn" control with instant response for realistic signature "quilling"
- **Odyssey II Speed Control** with On/Off switch
- Passenger car doors open by CAB remote control
- Authentically detailed interiors
- Directional lighting including prototypical marker lights
- Lighted destination and route boards on front and sides
- Dual powerful maintenance-free motors with momentum flywheels
- Die-cast metal trucks
- Minimum Curve: 0-36
- Set Length: 60"

6-31797 \$799.99

NEW YORK CITY TRANSIT AUTHORITY R16 SUBWAY 2-PACK

2-Pack Includes

- Two non-powered subway cars

Features

- Passenger car doors open by remote control when used with set
- Authentically detailed interiors
- Directional lighting including prototypical marker lights
- Lighted destination and route boards on front and sides
- Die-cast metal trucks
- Minimum Curve: 0-36
- Length: 30" (pair)

6-25595 \$399.99

"MTA" and associated terms and images are trademarks of the Metropolitan Transportation Authority.





OFFICIALLY
LICENSED

NEW



ICE COLD EXPRESS

A. BNSF ICE COLD EXPRESS

How cool is this? A modern AC6000 diesel, three mechanical reefers, and trailing scale caboose all decked out in an unforgettable styled version of the BNSF Ice Cold Express paint scheme. Inspired by the actual Ice Cold Express cars and the Lionel Collectors Club of America's 2009 Convention Car, this special set raises the creative bar of your scale-sized layout. Look closely to see the crisp and colorful icicle decoration that hangs near the roof of each freight car, and the icy snow that's built up on the AC6000 BNSF logo and cab number. Inside each of the high gloss, pearl white reefers you'll find something new. From one car you'll hear the mechanical sounds of the cooling generator, while a second operating reefer fills with "icy cold smoke". The third reefer comes packed with special box loads. Each of these 57' refrigerator cars also come equipped with a green "check light" near the door to show that refrigeration is in operation and ready to roll.

The scale BNSF AC6000 diesel that leads the BNSF Ice Cold Express comes equipped with Lionel's state-of-the-art features, including LEGACY Command Control, LEGACY RailSounds, Odyssey II speed control, and a wide variety of lighting options including ground lights and oscillating ditch lights.

Set Includes

AC6000 diesel locomotive, one operating mechanical refrigerator car with "ice cold" smoke, one operating mechanical refrigerator car with generator sounds, one mechanical refrigerator car with interior load, and one extended vision caboose

Locomotive Features

- **LEGACY Control System** equipped – able to run in LEGACY Control mode, in TrainMaster Command Control mode, or in Conventional mode with a standard transformer
- **Odyssey II Speed Control** with On/Off switch

• LEGACY RailSounds sound system featuring:

- CrewTalk dialog and TowerCom announcements, each with different scenarios depending on whether the locomotive is in motion or stopped
- Six official railroad speeds with CrewTalk dialog
- Eight diesel RPM levels
- LEGACY "Real-Time Quilling Horn" control with instant response for realistic signature "quilling" and correctly timed warning signals
- Single hit or continuous mechanical bell sounds

• Front and rear **ElectroCouplers**

- Dual powerful maintenance-free motors with momentum flywheels
- Refined Conventional Transformer Control Mode with lower starting speeds
- Traction tires
- Fan-driven smoke unit
- Adjustable smoke output
- Directional lighting including LED headlights
- Illuminated number boards
- Illuminated cab interior
- Oscillating ditch lights
- Ground lights
- Die-cast metal frame
- Separately applied metal details
- High gloss pearlescent paint
- Engineer and fireman figures

Rolling Stock Features

- Die-cast metal sprung trucks on refrigerator cars
- Die-cast metal trucks on caboose
- Operating couplers
- Hidden uncoupling tabs
- Separately applied metal underframe details
- Opening doors
- High gloss pearlescent paint
- Sliding compartment door on reefers reveals interior diesel engine
- Smoke unit with On/Off control on "ice cold" smoke reefer

- Generator sounds on sound reefer
- Illuminating green check light near door on reefers
- Interior illumination and exterior end lights on caboose
- Train crew figures in caboose
- Smoke unit with On/Off control on caboose
- Minimum Curve: 0-42
- Length: 76 1/2"

6-31783 \$999.99

B. 57' CRYO-TRANS MECHANICAL REFRIGERATOR CAR WITH EOT DEVICE

Cryo-Trans freight cars are a common site on the railways today. Specializing in the transporting frozen and perishable products, this colorful refrigerator features a blinking end-of-train device light at one end. Replace the caboose in your BNSF Ice Cold Express set with this eye-catching modern car, or add it to the end of any modern consist on your layout.

- Die-cast metal sprung trucks and operating couplers
- Hidden uncoupling tabs
- Rotating bearing caps
- Separately applied metal underframe details
- Opening doors
- Sliding compartment door on reefer reveals interior diesel engine
- Illuminating green check light near door
- Box loads and interior figure inside car
- Blinking end-of-train device light on one end
- Minimum Curve: 0-31
- Length: 15 1/2"

6-27278 \$94.99



Interior box loads



Sliding compartment door reveals engine



B

Includes box loads,
figure, and EOT device.



LEGACY
EQUIPPED



A

ALL ITEMS
NEW

19th CENTURY STOURBRIDGE LION

INCLUDES
DISPLAY BASE
WITH BRASS
PLATE

The very first steam locomotive to operate in the U.S.

HERITAGE SERIES STOURBRIDGE LION

Lionel's Heritage Series takes you back in time. Lionel is proud to offer the next locomotive in its popular Heritage Series—an exquisite replica of the historic 19th-century Stourbridge Lion locomotive. Equipped to operate in forward and reverse, this scale-sized 19th century locomotive is able to run on any 0-gauge layout including 0-27. 1:48th scale and accurately depicted in even the smallest details, Lionel's Stourbridge Lion features the highest level of quality and realism. Its compact "19th-century" size also makes the Stourbridge Lion the perfect display piece for an office desktop or home bookshelf. To securely display your locomotive and tender, a handsome display base is also included in the package.

Features

- Powered locomotive and tender
 - Brass and die-cast construction
 - Switch-controlled forward and reverse operation
 - Standard 0 scale model operates on 0-27 curves
 - Engineer figure
 - Limited production
 - Includes display base with track
 - Length: Loco and tender: Approx. 5"
Display base with brassplate: Approx. 15" (length of this base can accommodate locomotive, tender, and two coal cars)
- 6-11153** Heritage Series Stourbridge Lion Steam Locomotive **\$429.99**

Also Available:

STOURBRIDGE LION ANTHRACITE COAL CARS 2-PACK

- Brass and die-cast construction
- Removable coal loads
- Length: Approx. 4 1/2"

6-27426 \$129.99



Lion head image on front of boiler



Concept model shown

A BRIEF HISTORY OF THE STOURBRIDGE LION:

The 0-4-0 Stourbridge Lion was the very first steam locomotive to operate in the United States. Built in 1828 in England, it was imported to the U.S. by the Delaware & Hudson Canal Company to transport anthracite coal mined in Pennsylvania to New York City. This famous engine inherited its name from the town of Stourbridge in England where it was built, and from the dramatic lion's head painted on its boiler front. On August 8, 1829 the Stourbridge Lion made its first historic run in Honesdale, PA, the first operation of any steam locomotive in the United States. By 1834, the Stourbridge Lion was retired from service, and today the Smithsonian Institute possesses the pieces of what remains of the original engine. A full scale replica of the Stourbridge Lion was built by the D&H Railroad in 1933 for the Century of Progress Exposition in Chicago. This replica is on display at the Wayne County Historical Society & Museum in Honesdale, PA.



DEWITT CLINTON HERITAGE STEAM PASSENGER SET

LIONEL HERITAGE SERIES

DEWITT CLINTON HERITAGE STEAM PASSENGER SET

In 1831, the Mohawk & Hudson Railroad pioneered the first passenger train ever to run in the State of New York. Led by the famous DeWitt Clinton 0-4-0 steam locomotive the train included three passenger coaches that were in essence the same design as the typical horse-drawn stagecoaches of the era. At a speed of 30 mph, passengers rode the 17 mile stretch from Albany to Schenectady and back. For 14 years, this reliant train provided passenger service to the region and provided an early template for the nation's 19th century passenger lines.

In 1893, a replica of the DeWitt Clinton was built by New York Central and displayed at the Columbia Exposition in Chicago. In 1939, the famous steam locomotive was shown again at the New York World's Fair. Presently, the colorful DeWitt Clinton replica locomotive and coaches are on display at the Ford Museum in Dearborn, Michigan. Lionel now offers this important train in 1:48 scale as part of the Heritage Series of 19th century steam locomotives. The DeWitt Clinton Steam Passenger Set includes an 0-4-0 steam locomotive, tender, and three passenger cars. The set also includes a display base with brass name plate and figures for the coaches.



Set Includes

0-4-0 steam locomotive, tender, three coaches, display base

Features

- Powered locomotive and tender
- Brass and die-cast construction
- Switch-controlled forward and reverse operation
- Engineer figure on locomotive
- Passenger figures on each coach
- Standard O scale model
- Limited production
- Includes display base with brass nameplate (length of this base can accommodate locomotive, tender, and four coaches)
- Minimum Curve: 0-27
- Set Length: Approx. 17"

6-11164 Dewitt Clinton Heritage Steam Passenger Set **\$629.99**

Also Available

DEWITT CLINTON ADD-ON COACH

- Includes the same features found on coaches in set
- Length: Approx. 4"

6-11165 Dewitt Clinton Add-On Coach **\$69.99**

**INCLUDES
DISPLAY BASE
WITH BRASS
PLATE**



Concept model shown.

THE ORIGINAL SUPERPOWER

Created by the Lima Locomotive Company, Berkshires were among the last great steam locomotive designs and were dubbed the original "Superpowers". Both Nickel Plate Road and Pere Marquette railroads are well-known for their famous, restored 2-8-4 steamers that are still in operation today. Both locomotives have been involved in current excursion events and public display. Most recently, Nickel Plate #765 and Pere Marquette #1225 Berkshires, along with five other steam locomotives, operated at TrainFest 2009 in Owosso, MI to the delight of thousands of steamer fans.

Lionel's scale Berkshire locomotives come equipped with the latest LEGACY features and sounds, Odyssey II Speed Control, and feature superb detail including separately applied piping and accurate builder's plates. For both railroads, Lionel also offers a select offering of supporting scale rolling stock.

Locomotives Feature

- **LEGACY Control System** equipped – able to run in LEGACY Control mode, in TrainMaster Command Control mode, or in Conventional mode with a standard transformer
- **Odyssey II Speed Control** with On/Off switch
- Prototypical four chuffs per revolution
- Simulate the load running light or battling against a heavy load by manually adjusting the DynaChuff intensity with CAB-2 commands

- High-torque can motor with momentum flywheel
- **Wireless Tether** connection between locomotive and tender
- Operating headlight and classification lights
- Illuminated number boards
- Die-cast metal locomotive body, frame, and trucks
- Scale front coupler with interchangeable O gauge coupler for double heading
- Two traction tires
- Synchronized fan-driven smoke unit with adjustable smoke output
- Separately applied metal details
- Accurate, separately-applied builder's plates
- Authentically detailed cab interior
- Flickering firebox in cab
- Glass in cab windows
- Engineer and fireman figures

Tenders Feature

- **LEGACY RailSounds** sound system featuring:
 - CrewTalk dialog and TowerCom announcements, each with different scenarios depending on whether the locomotive is in motion or stopped
 - Six official railroad speeds with CrewTalk dialog
 - DynaChuff synchronized chuffing that shifts through 15 levels of intensity as the locomotive gains speed

- LEGACY "Real-Time Quilling Whistle" control with instant response for realistic signature "quilling" and correctly timed warning signals
- Single hit or continuous mechanical bell sounds
- Realistic operator-controlled effects, including the water injector
- Independently adjustable volume controlled effects such as whistle at full volume

- **ElectroCoupler** on rear of tender
- Dual FatBoy speakers for the ultimate in sound reproduction
- Operating back-up light on tender for directional lighting
- Die-cast metal body and trucks
- Separately applied metal details, including tender plates
- Minimum Curve 0-54
- Length: 26 1/2"

A. 6-11212 Nickel Plate #765 \$1399.99

B. 6-11203 Pere Marquette #1225 \$979.99 (engine only)

C. 6-11204 LEGACY RailSounds Pere Marquette Tender \$439.99 (tender only)



D

A



E



2-8-4 BERKSHIRE LOCOMOTIVES



B
C

Engine and tender sold separately.

D. NICKEL PLATE DOUBLE-SHEATHED BOXCAR

- Die-cast metal sprung trucks with operating couplers
- Hidden uncoupling tabs
- Separately applied metal underframe details
- Simulated wood-sheathed exterior
- Steam era Fishbelly-style underframe
- Opening doors
- Minimum Curve: 0-31
- Length: 11 1/2"

6-27276 \$69.99



E. NICKEL PLATE NORTHEASTERN CABOOSE

- Die-cast metal trucks and operating couplers
- Hidden uncoupling tabs
- Separately applied metal underframe details
- Smoke unit with On/Off control
- Train crew figure
- Interior illumination
- Detailed and painted interior
- Opening doors
- Minimum Curve: 0-31
- Length: 8 1/2"

6-27636 \$84.99



F. PERE MARQUETTE REGIONAL FREIGHT CAR 3-PACK

3-Pack Includes

- 6-27441 Detroit & Mackinac PS-2 Hopper
- 6-27273 Ann Arbor PS-1 Boxcar
- 6-27834 Pere Marquette PS-5 Gondola

Features

- Die-cast metal trucks and operating couplers
- Hidden uncoupling tabs
- Metal underframe details
- Boxcar also features opening doors and interior box loads
- Gondola also features auto frame load and opening drop ends
- Hopper also features rotating bearing caps, opening roof hatches, and die-cast metal ends
- Each car individually boxed
- Minimum Curve 0-31
- Length: 11 1/4" (boxcar)
14 1/2" (gondola)
10 1/4" (hopper)

6-31795 \$209.99

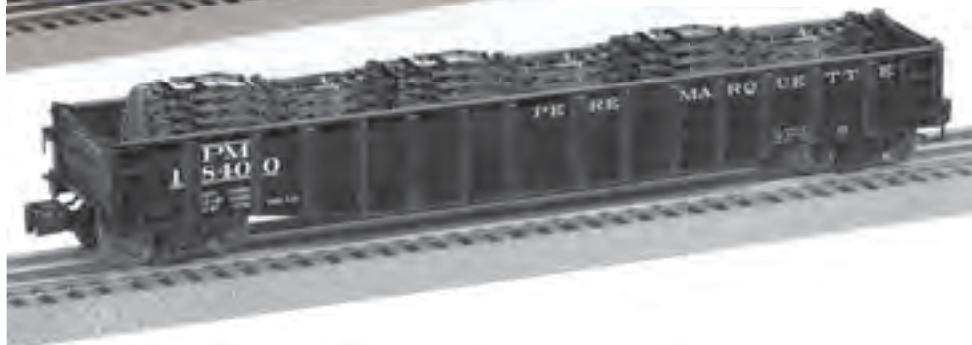

F

STEAM ENGINES



A. CANADIAN PACIFIC 4-6-0 TEN WHEELER STEAM LOCOMOTIVE

Round out your roundhouse with a 4-6-0 Ten-Wheeler! First built around the turn of the century, this jack-of-all-trades was able to survive the last fifty years of the steam era. Capable of hauling passenger and freight consists, the 4-6-0 ten-wheeler proved to be one of the most versatile locomotive designs.

- **Legacy Control System** equipped – able to run in LEGACY Control mode, in TrainMaster Command Control mode, or in Conventional mode with a standard transformer
- **Odyssey II Speed Control** with On/Off switch
- **LEGACY RailSounds** sound system featuring:
 - CrewTalk dialog and TowerCom announcements, each with different scenarios depending on whether the locomotive is in motion or stopped
 - Six official railroad speeds with CrewTalk dialog
 - DynaChuff synchronized chuffing that shifts through 15 levels of intensity as the locomotive gains speed
 - LEGACY “Real-Time Quilling Whistle” control with instant response for realistic signature “quilling” and correctly timed warning signals
 - Single hit or continuous mechanical bell sounds
- **Wireless Tether** connection between locomotive and tender
- **ElectroCoupler** on rear of tender
- Operating headlight and classification lights
- Illuminated number boards
- Die-cast metal locomotive body, frame, and trucks
- Traction tires
- Synchronized fan-driven smoke unit
- Separately applied metal details
- Accurate separately-applied builder’s plates
- Cab window glass
- Variable ashpan glow
- Engineer and fireman figures
- Die-cast metal tender body and trucks
- Minimum Curve: 0-31
- Length: 19 ½”

6-11202 \$739.99

B. WESTERN MARYLAND SHAY

Serving expanding lumber and coal industries, the Shay became the first locomotive able to penetrate thick forests and backwoods terrain where low speeds and high stability were essential. Western Maryland was one prominent railroad that put its trust in the rugged Shay to move Appalachian coal out of the region. The new Shay locomotive by Lionel features the famous fireball logo of Western Maryland, and comes equipped with Command Control and the RailSounds sound system.

- **Command Control** equipped – able to run in Command Control Mode or in Conventional Transformer Control Mode
- Speed control
- **RailSounds** sounds system with CrewTalk communication and TowerCom announcements
- DynaChuff synchronized chuffing
- Die-cast metal locomotive body, frame, and trucks
- Die-cast metal tender body and trucks with metal frame
- Separately applied metal details
- Fan-driven smoke unit with On/Off control
- **ElectroCoupler** on front and rear
- Directional lighting, including operating headlight and backup light
- Traction tires
- Firebox glow
- Engineer and fireman figures
- Minimum Curve: 0-54
- Length: 15 ½”

6-11157 \$799.99

C,D. SKELETON LOG CAR 2-PACKS

- Die-cast metal sprung trucks with operating couplers
- Die-cast metal body
- Realistic simulated log load
- Metal chains
- Minimum Curve: 0-31
- Length of single car: 9”

C. 6-27826 Canadian Pacific \$132.99

D. 6-27829 Western Maryland \$132.99





C



D



B

NEW

4-6-0 CAMELBACKS WITH LEGACY COMMAND CONTROL

A



B



C





ALL ITEMS
NEW



Once popular in freight and passenger service, the distinctive wide firebox of the Camelback allowed it to burn cheap wasted anthracite coal common on many eastern railroads. Now for the first time, the popular Camelback 4-6-0 is available by Lionel equipped with the LEGACY Control System and LEGACY RailSounds. Offered in three eastern road names, this scale-sized engine is packed with accurate detail and high-end features, and is fit to run on a wide variety of layout curves.

Add supporting steam era freight cars that are available in the Lehigh Valley, Jersey Central, and Pennsylvania paint schemes. Each car in the 2-packs is individually boxed.

- **LEGACY Control System** equipped – able to run in LEGACY Control mode, in TrainMaster Control mode, or in Conventional mode with a standard transformer
- **Odyssey II Speed Control** with On/Off switch
- **LEGACY RailSounds sound** system featuring:
 - CrewTalk dialog and TowerCom announcements, each with different scenarios depending on whether the locomotive is in motion or stopped
 - Six official railroad speeds with corresponding CrewTalk dialog
 - DynaChuff synchronized chuffing with 15 levels of intensity as the locomotive gains speed
 - LEGACY “Real-Time Quilling Whistle” control with instant response for realistic signature ‘quilling’ and correctly timed warning signals
 - Single hit or continuous bell sounds
- Powerful maintenance-free motor with momentum flywheel
- **ElectroCoupler** on rear of tender

- Directional lighting including operating headlight and back-up light on rear of tender
- Illuminated classification lights on the front of locomotive
- Two traction tires
- Fan-driven smoke unit
- Die-cast metal locomotive body, pilot, and trucks
- Die-cast metal tender body and trucks
- Separately applied metal details
- Opening roof hatch
- Opening tender water hatch reveals easy-to-access controls
- Authentically detailed cab interior
- Interior illumination in cab
- Glowing firebox behind cab
- Cab glass windows
- Engineer and fireman figures
- Minimum Curve: 0-31
- Length: 17 ½”

- A. 6-11215 Lehigh Valley \$549.99
- B. 6-11216 Jersey Central \$549.99
- C. 6-11217 Pennsylvania \$549.99

STEAM ERA FREIGHT CARS

Caboose Feature

- Die-cast metal trucks and operating couplers
- Hidden uncoupling tabs
- Separately applied metal underframe details
- Smoke unit with On/Off control
- Train crew figure
- Interior illumination

- Detailed and painted interior
- Opening doors
- Minimum Curve: 0-31
- Length: 8 ½”

Boxcars Feature

- Die-cast metal sprung trucks and operating couplers
- Hidden uncoupling tabs
- Separately applied metal underframe details
- Simulated wood-sheathed exterior
- Steam era Fishbelly-style underframe
- Opening doors
- Minimum Curve: 0-31
- Length: 11 ½”

D. JERSEY CENTRAL FREIGHT CAR 2-PACK

2-Pack Includes

- 6-27644 Jersey Central Caboose
- 6-27290 Jersey Central Double-sheathed Boxcar
- 6-27289 \$159.99

E. LEHIGH VALLEY FREIGHT CAR 2-PACK

2-Pack Includes

- 6-27643 Lehigh Valley Caboose
- 6-27288 Lehigh Valley Double-sheathed Boxcar
- 6-27287 \$159.99

F. PENNSYLVANIA DOUBLE-SHEATHED BOXCAR

- 6-27291 \$69.99

BALTIMORE & OHIO

A. BALTIMORE & OHIO FA-2 AA SET

In the mid-1940s, the American Locomotive Company added a new freight diesel, the FA, to its roster. Beginning in 1950, a higher horsepower FA-2 replaced the original FA units, with the first of them delivered to the Baltimore & Ohio and Erie railroads. In their day, the FA competed head-on with the popular F-units of EMD and is considered by many to be among the most handsome diesel locomotives ever built. These 1600 horsepower freight engines went on to serve a multitude of railroads across the nation for decades.

Lionel proudly offers the first LEGACY version of the FA-2 scale diesel in a two-unit set under the banner of Baltimore & Ohio. Dressed in classic B&O blue, grey, and black colors, this handsome A-A set comes equipped with the best of features including LEGACY Command Control, LEGACY RailSounds, and Odyssey II speed control.

Set Includes

One powered A-unit and one non-powered A-unit

Both A-Units Feature

- Front **Electrocoupler**
- Fan-driven smoke unit
- Adjustable smoke output
- Directional lighting, including LED headlights
- Illuminated number boards
- Illuminated cab interior
- Die-cast metal trucks, pilot, and fuel tank
- Metal frame
- Pivoting vestibules on rear
- Separately applied metal details
- Engineer and fireman figures

Powered A-Unit Also Features

- **LEGACY Control System** equipped – able to run in LEGACY Control mode, in TrainMaster Command Control mode, or in Conventional mode with a standard transformer

Odyssey II Speed Control

- **LEGACY RailSounds** sound system featuring:

- CrewTalk dialog and TowerCom announcements, each with different scenarios depending on whether the locomotive is in motion or stopped
- Six official railroad speeds with CrewTalk dialog
- Eight diesel RPM levels
- LEGACY "Real-Time Quilling Horn" control with instant quilling and correctly timed warning signals
- Single hit or continuous mechanical bell sounds
- Dual powerful maintenance-free motors with momentum flywheels
- Refined Conventional Transformer Control mode with lower starting speeds
- Traction tires
- Minimum Curve: 0-31
- Set Length: 27"

6-34570 \$649.99

B. BALTIMORE & OHIO I-12 CABOOSE

The famous I-12 caboose is back again in a new scheme that features a large size B&O Capital logo. Sharp looking in rich blue with yellow lettering and striping, the full scale I-12 caboose features a wealth of accurate detail and decoration inside and out.

- Die-cast metal sprung trucks
- Hidden uncoupling tabs
- Separately applied metal underframe details
- Smoke unit with On/Off control
- Detailed and painted interior
- Operating marker lights
- Opening doors
- Interior illumination
- Train crew figures
- Minimum Curve: 0-31
- Length: 9 1/2"

6-27635 \$84.99





2-PACK

C. BALTIMORE & OHIO PS-1 BOXCAR 2-PACK

Two of the most famous "Fast Freight" paint schemes ever on the rails are now available on Lionel's highly-detailed scale boxcar. Built in 1945 and 1947, the B&O "Sentinel" and the "Time-Saver" boxcars were relied on for fast dependable service for many years on the Baltimore & Ohio railroad lines.

2-Pack Includes

- 6-27271 B&O "Time-Saver" PS-1 Boxcar
- 6-27272 B&O "Sentinel" PS-1 Boxcar

Features

- Die-cast metal sprung trucks and operating couplers
- Separately applied metal underframe details
- Opening doors
- Box loads in interior
- Each car in pack individually boxed
- Minimum Curve: 0-31
- Length: 11 1/4" each

6-27270 \$139.99



D, E, F. EARLY ERA INSPECTION VEHICLES

The excitement never ends with this all new introduction from Lionel! These **die-cast metal, scale** rail inspection cars are equipped with working headlights and are sure to add some fun to your train operating. Reminiscent of early classics intended for use in railroad maintenance they add an additional touch of prototypical realism. Designed to operate on curves as tight as 0-27, they are visually accurate all the way to the locomotive looking cowcatcher on the front.

See your dealer to pick one favorite or purchase all three, just don't miss this exciting new scale offering from Lionel!

- Powerful maintenance-free motor
- Standard O scale model operates on 0-27 curves
- Operates in forward, neutral and reverse
- Detailed die-cast metal body and frame
- Operating headlights
- Minimum Curve: 0-27
- Approx. Length: 5 1/2"

D. 6-28454 CANADIAN PACIFIC \$129.99

E. 6-28452 M.O.W. \$129.99

F. 6-28453 PENNSYLVANIA \$129.99

SOUTHERN PACIFIC

A. SOUTHERN PACIFIC FM TRAINMASTER DIESEL LOCOMOTIVE

With 2,400 horsepower and a great deal of new technology these locomotives stormed onto the scene in the early 1950s. Ahead of their time, the impressive debut was somewhat diminished when they were found to be a challenge and costly when it came to maintenance.

The Southern Pacific Railroad used their beautiful 'Black Widow' paint scheme on these powerful workhorses, creating quite a sight as they hauled freight down the line. By the 1960s the once prominent diesels were relegated to commuter operation in California and the heyday of the Southern Pacific Trainmaster became a thing of the past. By the 1970s only the memories and a few commuters remained.

You can bring back those early days with this awesome recreation from Lionel. Complete with all the technology that the LEGACY Control System evokes, including the industry best LEGACY RailSounds.

- **LEGACY Control System** equipped – able to run in LEGACY Control mode, in Command Control mode, or in Conventional mode with a standard transformer
- **Odyssey II Speed Control** with On/Off switch
- **LEGACY RailSounds** sound system featuring:
 - CrewTalk dialog and TowerCom announcements, each with different scenarios depending on whether the locomotive is in motion or stopped
 - Six official railroad speeds with CrewTalk dialog
 - Eight diesel RPM levels
 - LEGACY "Real-Time Quilling Horn" control with instant response for realistic signature "quilling" and correctly timed warning signals
 - Single hit or continuous mechanical bell sounds
- Dual, powerful maintenance-free motors with momentum flywheels
- Traction tires
- Fan-driven smoke unit with adjustable smoke output
- Front and rear **ElectroCouplers**
- Directional lighting, including LED headlights
- Operating radiator fans
- Separately applied metal vent screens and handrails
- Die-cast metal pilots, fuel tanks, and trucks
- Metal frame
- Accurate, separately applied builder's plates
- Illuminated number boards
- Illuminated cab interior
- Engineer and fireman figures
- Minimum Curve: 0-31
- Length: 16 ½"

6-28341 \$494.99

B. SOUTHERN PACIFIC PS-1 OVERNIGHT BOXCAR

- Die-cast sprung metal trucks and operating couplers
- Hidden uncoupling tabs
- Metal underframe detail
- Opening doors
- Box loads in interior
- Minimum Curve: 0-31
- Length: 11 ¼"

6-27275 \$69.99

C. SOUTHERN PACIFIC ALCO PA A-A SET

There is probably no more recognized or outstanding paint scheme in the world of trains than the dynamic and awe inspiring Southern Pacific 'Daylight' pattern. First conceptualized in the 1930s, the colorful scheme was so well received and such a beautiful presentation that the SP included it on many of their diesel and steam passenger consists for decades.

That storied and historically significant paint comes to life with these new offerings from Lionel. High in detail with dual front lights and realistic looking number boards, this set will be sure to capture your eye and your heart. Inspired by the fantastic Southern Pacific passenger trains of an era gone by these fabulous locomotives can now find a place of significance on your layout, too.

Consider creating a full lash-up by adding the separately available powered PB B unit.

Look for matching 18" passenger cars in the next catalog!

A-A PA Set Includes

Powered A-unit and Non-powered A-unit

Both A-Units Feature

- Front **Electrocoupler**
- Fan-driven smoke unit
- Adjustable smoke output in LEGACY Control or TMCC mode
- Directional lighting, including LED headlights
- Mars light on front
- Illuminated number boards
- Illuminated cab interior
- Die-cast metal trucks, pilot, and fuel tank
- Metal frame
- Separately applied metal details

Powered A Unit Also Features

- **LEGACY Control System** equipped – able to run in LEGACY Control mode, in TrainMaster Command Control mode, or in Conventional mode with a standard transformer
- **Odyssey II Speed Control** with On/Off switch
- **LEGACY RailSounds** sound system featuring:
 - CrewTalk dialog and TowerCom announcements, each with different scenarios depending on whether the locomotive is in motion or stopped
 - Six official railroad speeds with CrewTalk dialog

-Eight diesel RPM levels

-LEGACY "Real-Time Quilling Horn" control with instant quilling and correctly timed warning signals

-Single hit or continuous mechanical bell sounds

- Dual powerful maintenance-free motors with momentum flywheels
- Refined Conventional Transformer Control mode with lower starting speeds
- Traction tires
- Engineer and fireman figures
- Minimum Curve: 0-31
- Length: A-A Set 34"

6-34564 \$749.99

D. SOUTHERN PACIFIC ALCO PB POWERED B UNIT

- **LEGACY Control System** equipped – able to run in LEGACY Control mode, in TrainMaster Command Control mode, or in Conventional mode with a standard transformer
- **Odyssey II Speed Control** with On/Off switch
- Fan-driven smoke unit
- Rear **ElectroCoupler**
- Dual powerful maintenance-free motors with momentum flywheels
- Refined Conventional Transformer Control mode with lower starting speeds
- Die-cast metal trucks and fuel tanks
- Metal frame
- Traction tires
- Minimum Curve: 0-31
- Length: 16 ¾"

6-34567 \$399.99

LEGACY
EQUIPPED





A



B

ALL ITEMS
NEW



C



D



AMTRAK

A. HHP-8 ELECTRIC LOCOMOTIVE

By popular demand, the HHP-8 is now available with the RailSounds sound system. In addition to dual motors for extra pulling power, this electric also features opening doors and realistic pantographs that raise and lower manually.

- Command Control equipped – able to run in Command Control mode or in Conventional Transformer Control mode
- **RailSounds** sound system
- Realistic horn and bell
- Dual powerful maintenance-free motors
- Minimum Curve:
- Length:

6-38402 \$399.99

B. AMTRAK DASH 9

General Electric's Dash 9 is one of the most identifiable locomotives to ever run the American rails. Generating close to 4,500 horsepower with its electronic fuel injection engines, its impressive performance made it popular railroads. Packed with all of your favorite features, this engine is finely detailed with safety treads along the side walkways, emergency placards printed on the top and sides of its scale-sized body, and it's equipped with a smoother running, dual motor system and impressive fan driven smoke unit. For the first time, Lionel's Dash 9 in the Amtrak road name can be experienced in the ultra-realism of LEGACY RailSounds, and Odyssey II speed control, and the LEGACY Command System.

- **LEGACY Control System** equipped – able to run in LEGACY Control mode, in TrainMaster Command Control mode, or in Conventional mode with a standard transformer
- **Odyssey II Speed Control** with On/Off switch
- **LEGACY RailSounds** sound system featuring:
 - CrewTalk dialog and TowerCom announcements, each with different scenarios depending on whether the locomotive is in motion or stopped
 - Six official railroad speeds with CrewTalk dialog

- Eight diesel RPM levels
- LEGACY "Real-Time Quilling Horn" control with instant quilling and correctly timed warning signals
- Single hit or continuous mechanical bell sounds

- Dual powerful maintenance-free motors with momentum flywheels
- Refined Conventional Transformer Control mode with lower starting speeds
- Traction tires
- **Electrocoupler** on front and rear
- Fan-driven smoke unit
- Adjustable smoke output
- Directional lighting, including LED headlights and operating marker lights
- Illuminated number boards
- Illuminated cab interior
- Die-cast metal trucks, pilot, and fuel tank
- Metal frame
- Separately applied metal details
- Engineer and fireman figures
- Minimum Curve: 0-36
- Length: 18"

6-28343 \$499.99

AMFLEET COACHES

All Amfleet Cars on Pages 38-39 Feature

- Die-cast metal trucks and operating couplers
- Flush fitting windows
- Interior illumination
- Metal frames
- Detailed interiors
- Separately applied underside details
- Unique road number on each Amfleet car
- Minimum Curve: 0-36
- Length: 18" single car

C. AMFLEET CAB CONTROL END CAR

In push-pull service, a locomotive pulls a commuter train in only one direction. When reversed, the locomotive is controlled remotely from a "control cab" car at the opposite end of the train.

Create your own push-pull commuter train with the Amfleet Cab Control End Car. When you put your diesel engine in reverse, the yellow striped end car takes the lead in your passenger consist, simulating cab-control operations on the real railroads!

Additional Features

- Operating headlight
- Operating red marker lights
- Operating strobe light on roof
- Horn details on roof
- Driver figure
- On/Off interior light switch
- On/Off strobe light switch
- Length: Approximately 19"

6-35454 \$89.99

D. AMFLEET PHASE IVB COACH 2-PACK

These two newly-numbered coach class cars are a realistic fit between the Amtrak Dash 9 and the Cab Control End Car, or behind your HHP-8 electric.

6-35433 \$139.99

E. AMFLEET "CAPSTONE" COACH 3-PACK

As part of the Capstone rebuild project, many Amfleet commuter cars were repaired in an Acela-like scheme that was highlighted by a lively turquoise stripe through the windows. Each car is uniquely numbered in this 3-pack outfit.

6-35473 \$179.99

NEWLY TOOLED
END PIECE ON CAB
CONTROL CAR



RAILSOUNDS AND
DUAL MOTORS



A



B



C



GP-7 DIESEL LOCOMOTIVES

Produced from 1949 to the mid-1950s, more than 2,500 prototype EMD GP7 locomotives hauled freight across the United States and Canada. Available in three different road names, the classic GP7 of Lionel comes fully equipped with the LEGACY Control System. New in 2010, the vibrant Western Pacific GP-7 joins the line.

- **LEGACY Control System** equipped – able to run in LEGACY Control mode, in TrainMaster Command Control mode, or in Conventional mode with a standard transformer
- **Odyssey II Speed Control** with On/Off switch
- **LEGACY RailSounds** sound system featuring:
 - CrewTalk dialog and TowerCom announcements, each with different scenarios depending on whether the locomotive is in motion or stopped
 - Six official railroad speeds with CrewTalk dialog
 - Eight diesel RPM levels
 - LEGACY “Real-Time Quilling Horn” control with instant response for realistic signature “quilling” and correctly timed warning signals
 - Single hit or continuous mechanical bell sounds
- Front and rear **ElectroCouplers**

- Dual powerful maintenance-free motors with momentum flywheels
- Refined Conventional Transformer Control Mode with lower starting speeds
- Traction tires
- Fan-driven smoke unit
- Adjustable smoke output
- Directional lighting including LED headlights
- Operating marker lights
- Illuminated number boards
- Illuminated cab interior
- Die-cast metal trucks, pilot, and fuel tank
- Metal frame
- Separately applied metal details
- Engineer and fireman figures
- Minimum Curve: 0-31
- Length: 14 ¼”

- A. **6-28598** Santa Fe \$449.99
- B. **6-28587** Pennsylvania #8510 \$449.99
- C. **6-28340** Western Pacific \$449.99

D. FEATHER ROUTE FREIGHT CAR 3-PACK

- 3-Pack Includes**
- 6-27277 Western Pacific PS-1 Boxcar
 - 6-27843 Western Pacific PS-5 Gondola
 - 6-27842 Union Pacific Flatcar with Bulkheads

Features

- Die-cast metal trucks and operating couplers
- Hidden uncoupling tabs
- Separately applied metal underframe details
- Boxcar also features opening doors
- Flatcar also features real wood deck, die-cast metal body, and metal pipe load
- Gondola also features auto frame load and opening drop ends
- Each car individually boxed in pack
- Minimum Curve 0-31
- Length: 11 ¼” (boxcar)
- 14 ¾” (flatcar)
- 14 ½” (gondola)

6-31796 \$209.99



NEW

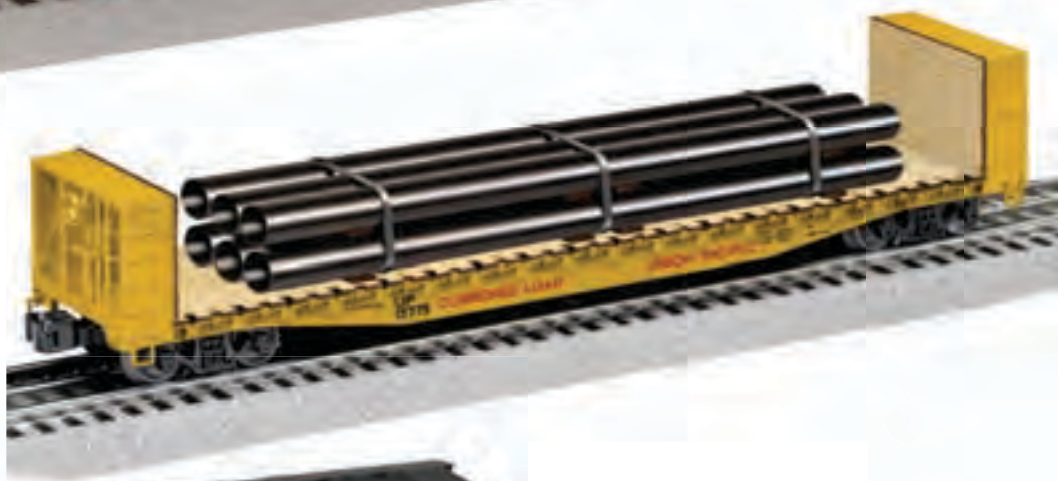

**3-PACK
NEW**

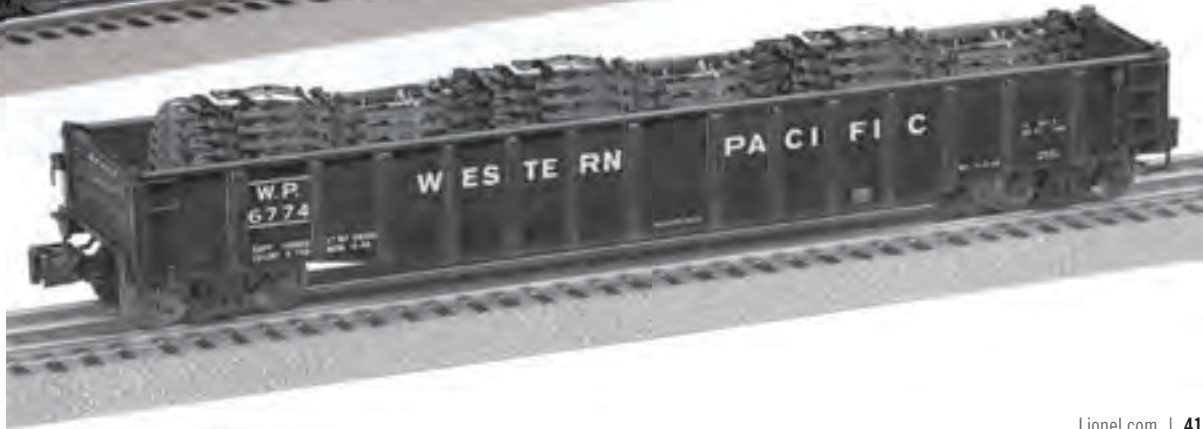

BURLINGTON NORTHERN



A



B



C





ALL ITEMS
NEW

B. BURLINGTON NORTHERN SD60 DIESEL

A king of the modern rails, the SD-60 diesel from EMD is a freight hauling brute. At 3,800 horsepower, this six-axle locomotive was a mainstay for a variety of railroads since it was first introduced in 1984.

Scale-sized, equipped with dual motors and the full pallet of LEGACY features, the new Lionel SD-60 is now available in Burlington Northern livery. Painted in the distinguished green of BN, this diesel engine also sports the alternate "Tiger Stripe" paint scheme on the cab nose which was added by BN to increase locomotive visibility.

- **LEGACY Control System** equipped – able to run in LEGACY Control mode, in TrainMaster Command Control mode, or in Conventional mode with a standard transformer
- **Odyssey II Speed Control** with On/Off switch
- **LEGACY RailSounds** sound system featuring:
 - CrewTalk dialog and TowerCom announcements, each with different scenarios depending on whether the locomotive is in motion or stopped
 - Six official railroad speeds with CrewTalk dialog
 - Eight diesel RPM levels
 - LEGACY "Real-Time Quilling Horn" control with instant quilling and correctly timed warning signals
 - Single hit or continuous mechanical bell sounds
- Dual powerful maintenance-free motors with momentum flywheels
- Directional lighting including LED headlights
- Operating marker lights
- Operating ditch lights
- **ElectroCoupler** on front and rear
- Refined Conventional Transformer Control mode with lower starting speeds
- Traction tires
- Fan-driven smoke unit
- Adjustable smoke output
- Illuminated number boards
- Illuminated cab interior
- Die-cast metal trucks, pilot, and fuel tank
- Metal frame

- Separately applied metal details
- Engineer and fireman figures
- Minimum Curve: 0-31
- Length: 18"

6-28312 \$499.99

C. BURLINGTON NORTHERN COMMAND CRANE CAR

Nothing in O Gauge operating cars matches the hi-tech operation of a Lionel scale command control crane car. Available now in Burlington Northern, the crane boasts such features as 360 degree cab rotation, control of the big boom, individual control of the hook lines, and more – all operable through your remote cab unit. Command Control or LEGACY CAB Remote Controller and Base required.

- Four powerful, maintenance-free motors
- Die-cast metal six-wheel sprung trucks
- Front and rear **ElectroCouplers**
- Die-cast metal body, frame, and boom
- Operating front and rear work lights
- Opening cab doors
- 12 outrigger supports included for use on traditional O gauge, O- 27, or FasTrack track systems
- Minimum Curve: 0-31
- Length: 10 ¾"

6-29885 \$339.99

A. BURLINGTON NORTHERN COMMAND BOOM CAR

The experience is complete with the addition of the BN Boom Car, which provides realistic crew and crane sounds synchronized perfectly with the various actions of the BN Crane Car. Listen as the engine sputters and comes to life. Hear the gears of the hook engage. Deploy the outriggers and hear the sounds of the steel girders snapping into place.

- **Command Control** equipped
- **RailSounds** sound system, including engine revving, air horn, couplers, and multi-part crew/foreman dialog
- Synchronized boom, winch, and outrigger effects
- Special start-up and shut down sequences
- Die-cast metal trucks and operating couplers

- Die-cast metal flatcar
- Wood flatcar deck
- Metal underframe details
- Minimum Curve: 0-31
- Length: 11 ¼"

6-29886 \$219.99

D. BURLINGTON NORTHERN CYLINDRICAL HOPPER

- Die-cast metal sprung trucks and operating couplers
- Hidden uncoupling tabs
- Rotating bearing caps
- Opening roof hatches
- Minimum Curve: 0-31
- Length: 13 ¾"

6-27440 \$79.99

NORFOLK SOUTHERN HERITAGE LINE

By popular demand, Lionel continues its tribute to the rich heritage of the Norfolk Southern with a new selection of colorful Heritage diesels and rolling stock.

Four important railroads that were ultimately absorbed into modern day Norfolk Southern are being honored in this catalog, including Southern, Virginian, Norfolk & Western, and Conrail.

Each collector's locomotive in this Heritage line is beautifully and uniquely decorated by Lionel to pay tribute to the Norfolk Southern Railway and the fallen flag railroads it was built from.

A, B. SD70ACe Heritage Diesels

- **Legacy Control System** equipped – able to run in LEGACY Control mode, in TrainMaster Command Control mode, or in Conventional mode with a standard transformer
- **Odyssey II Speed Control** with On/Off switch
- **LEGACY RailSounds** sound system featuring:
 - CrewTalk dialog and TowerCom announcements, each with different scenarios depending on whether the locomotive is in motion or stopped
 - Six official railroad speeds with CrewTalk dialog
 - Eight diesel RPM levels
 - LEGACY “Real-Time Quilling Horn” control with instant response for realistic signature “quilling” and correctly

- timed warning signals
- Single hit or continuous mechanical bell sounds
- Front and rear **ElectroCouplers**
- Dual powerful maintenance-free motors with momentum flywheels
- Refined Conventional Transformer Control Mode with lower starting speeds
- Traction tires
- Fan-driven smoke unit
- Adjustable smoke output
- Directional lighting including LED headlights
- Operating marker lights
- Illuminated number boards
- Illuminated cab interior
- Oscillating ditch lights
- Ground lights
- Die-cast metal trucks, pilot, and fuel tank
- Metal frame
- Separately applied metal details
- Engineer and fireman figures
- Minimum Curve: 0-36
- Length: 17 ½”

A. 6-28333 Virginian Heritage **\$499.99**
B. 6-28318 Conrail Heritage **\$499.99**

C. NS HERITAGE VIRGINIAN 3-BAY OPEN HOPPER

- Die-cast metal sprung trucks
- Hidden uncoupling tabs
- Die-cast metal frame and body
- Rotating bearing caps
- Removable single-piece coal load
- Opening bottom hatches
- Minimum Curve: 0-31
- Length: 12 ¾”

6-27438 **\$79.99**

D. NS HERITAGE CONRAIL CYLINDRICAL HOPPER

- Die-cast metal sprung trucks and operating couplers
- Hidden uncoupling tabs and rotating bearing caps on trucks
- Opening roof hatches
- Minimum Curve: 0-31
- Length: 13 ¾”

6-27433 **\$79.99**





B



D

ALL ITEMS
NEW



E



F

E, F. NS HERITAGE CA-4 CABOSES

- Hidden uncoupling tabs
- Die-cast metal trucks
- Separately applied metal underframe details
- Smoke unit with On/Off control
- Interior illumination
- Train crew figures
- Minimum Curve: 0-31
- Length: 10"

E. 6-29735 Conrail Heritage \$94.99

F. 6-27630 Virginian Heritage \$94.99

NORFOLK SOUTHERN HERITAGE DIESELS

SD70ACe NORFOLK SOUTHERN HERITAGE DIESELS

Each collector's locomotive in this Heritage line is beautifully and uniquely decorated to pay special tribute to the Norfolk Southern Railway and the fallen flag railroads it was built from.

- **Legacy Control System** equipped – able to run in LEGACY Control mode, in TrainMaster Command Control mode, or in Conventional mode with a standard transformer
- **Odyssey II Speed Control** with On/Off switch
- **LEGACY RailSounds** sound system featuring:
 - CrewTalk dialog and TowerCom announcements, each with different scenarios depending on whether the locomotive is in motion or stopped
 - Six official railroad speeds with CrewTalk dialog

- Eight diesel RPM levels
- LEGACY "Real-Time Quilling Horn" control with instant response for realistic signature "quilling" and correctly timed warning signals
- Single hit or continuous mechanical bell sounds
- Front and rear **ElectroCouplers**
- Dual powerful maintenance-free motors with momentum flywheels
- Refined Conventional Transformer Control Mode with lower starting speeds
- Traction tires
- Fan-driven smoke unit
- Adjustable smoke output
- Directional lighting including LED headlights
- Operating marker lights

- Illuminated number boards
- Illuminated cab interior
- Oscillating ditch lights
- Ground lights
- Die-cast metal trucks, pilot, and fuel tank
- Metal frame
- Separately applied metal details
- Engineer and fireman figures
- Minimum Curve: 0-36
- Length: 17 1/2"
- A. 6-28344 Southern Heritage \$499.99**
- B. 6-28345 Norfolk & Western Heritage \$499.99**





C

C. NS HERITAGE SOUTHERN CYLINDRICAL HOPPER

- Die-cast metal sprung trucks and operating couplers
- Hidden uncoupling tabs and rotating bearing caps on trucks
- Opening roof hatches
- Minimum Curve: 0-31
- Length: 13 3/4"

6-27446 \$79.99



D

D. NS HERITAGE N&W PS-2CD HOPPER

- Die-cast metal sprung trucks and operating couplers
- Hidden uncoupling tabs and rotating bearing caps on trucks
- Die-cast metal end platforms and etched metal roofwalks
- Minimum Curve: 0-31
- Length: 13 3/4"

6-27445 \$79.99



E



F

NS HERITAGE CA-4 CABOSES

- Hidden uncoupling tabs
- Die-cast metal sprung trucks
- Separately applied metal underframe details
- Smoke unit with On/Off control
- Interior illumination
- Train crew figures
- Minimum Curve: 0-31
- Length: 10"

E. 6-27639 NS Heritage Norfolk & Western \$94.99

F. 6-29734 NS Heritage Pennsylvania \$94.99

G. 6-27638 NS Heritage Southern \$94.99



G

SANTA FE

A. SANTA FE WARBONNET AC6000

The most famous locomotive paint scheme of all – the Santa Fe Warbonnet resplendent in silver and red. Reminiscent of a Native American headdress, this dramatic red bonnet paint scheme was conceived in the 1930s for the railroad's premier passenger fleet. Long-lasting, the red and silver scheme could also be found into the 1980s on Santa Fe freight diesels. But the Burlington Northern merger that came in 1998 put an end to the Santa Fe's reign and an end to the Warbonnet on Santa Fe diesels.

What if Santa Fe was still intact today and possessed a new modern fleet of diesel locomotives? This question is answered with the new Santa Fe AC6000 diesel, one of the most powerful brutes on the rails today. This modern 6000 horsepower diesel measures 76 feet from coupler to coupler in real life, and comes equipped with state of the art technology that controls emission levels and fuel consumption.

Never before seen, this modern warhorse is decorated in special Warbonnet paint scheme of Santa Fe. It comes fully equipped with the LEGACY Controls System, LEGACY RailSounds, and Odyssey II Speed Control. Update your selection of scale Santa Fe Warbonnet engines to include one of the great modern locomotives, the AC6000 diesel.

- **LEGACY Control System** equipped – able to run in Legacy Control mode, in TrainMaster Command Control mode, or in Conventional mode with a standard transformer
- **Odyssey II Speed Control** with On/Off switch
- **LEGACY RailSounds** sound system featuring:
 - CrewTalk dialog and TowerCom announcements, each with different scenarios depending on whether the locomotive is in motion or stopped
 - Six official railroad speeds with CrewTalk dialog
 - Eight diesel RPM levels
 - LEGACY "Real-Time Quilling Horn" control with instant response for realistic signature "quilling" and correctly timed warning signals
 - Single hit or continuous mechanical bell sounds
- Front and rear **ElectroCouplers**
- Dual powerful maintenance-free motors with momentum flywheels
- Refined Conventional Transformer Control Mode with lower starting speeds
- Traction tires
- Fan-driven smoke unit
- Adjustable smoke output
- Directional lighting including LED headlights
- Illuminated number boards
- Illuminated cab interior
- Oscillating ditch lights
- Ground lights
- Die-cast metal trucks, pilot, and fuel tank
- Die-cast metal frame
- Separately applied metal details
- Engineer and fireman figures
- Minimum Curve: 0-42
- Length: 19 ½"

6-28339 \$549.99

B. SANTA FE 57' MECHANICAL REFRIGERATOR CAR

- Die-cast metal trucks and operating couplers
- Hidden uncoupling tabs
- Rotating bearing caps
- Separately applied detail parts
- Opening doors
- Sliding compartment door reveals diesel engine
- Minimum Curve: 0-31
- Length: 14 ¼"

6-27294 \$84.99

C. SANTA FE WARBONNET EXTENDED VISION CABOOSE

- Die-cast metal sprung trucks and operating couplers
- Hidden uncoupling tabs
- Rotating bearing caps
- Separately applied detail parts
- Smoke with On/Off switch
- Train crew figures
- Detailed and painted interior
- Interior illumination
- Exterior end lights
- Opening end doors
- Minimum Curve: 0-31
- Length: 10 ¼"

6-27634 \$84.99





SCALE FREIGHT CARS

A. VIRGINIAN PS-1 BOXCAR

- Die-cast metal sprung trucks and operating couplers
 - Separately applied metal underframe details
 - Opening doors
 - Box loads in interior
 - Minimum Curve: 0-31
 - Length: 11 1/4"
- 6-27265 \$69.99

B. GATX TANKTRAIN

- Die-cast metal sprung trucks and operating couplers
 - Hidden uncoupling tabs
 - New road numbers
 - Separately applied metal details
 - Minimum Curve: 0-31
 - Length: 10"
- 6-27412 \$69.99

UNION PACIFIC FREIGHT CARS

Support your VISIONLine U.P. Challengers with these two new U.P. freight cars.

C. UNION PACIFIC ACF STOCK CAR

- Die-cast metal sprung trucks and operating couplers
- Hidden uncoupling tabs
- Die-cast metal frame

- Metal underframe details
 - Opening doors
 - Four hand-painted cattle figures included
 - Minimum Curve: 0-31
 - Length: 11 1/2"
- 6-17720 \$69.99

D. UNION PACIFIC DOUBLE-DOOR BOXCAR

- Die-cast metal trucks and operating couplers
 - Hidden uncoupling tabs
 - Separately applied metal underframe details
 - Opening side doors
 - Auto rack load
 - Minimum Curve: 0-31
 - Length: 14"
- 6-27282 \$69.99

E. CLINCHFIELD FREIGHT CAR 2-PACK

A great add-on to the VISIONLINE Clinchfield Challenger.

2-Pack Includes

- 6-27062 Clinchfield Offset Hopper
- 6-27281 Clinchfield Double-sheathed Boxcar

Features

- Hidden uncoupling tabs
 - Separately applied metal underframe details
 - Opening doors and interior load in boxcar
 - Die-cast metal body and opening bottom hatches on hopper
 - Removable coal load and prototypical curved ends on hopper
 - Each car individually boxed
 - Minimum Curves: 0-31
 - Length: Boxcar: 11 1/2"
Hopper: 9 1/2"
- 6-27061 \$149.99



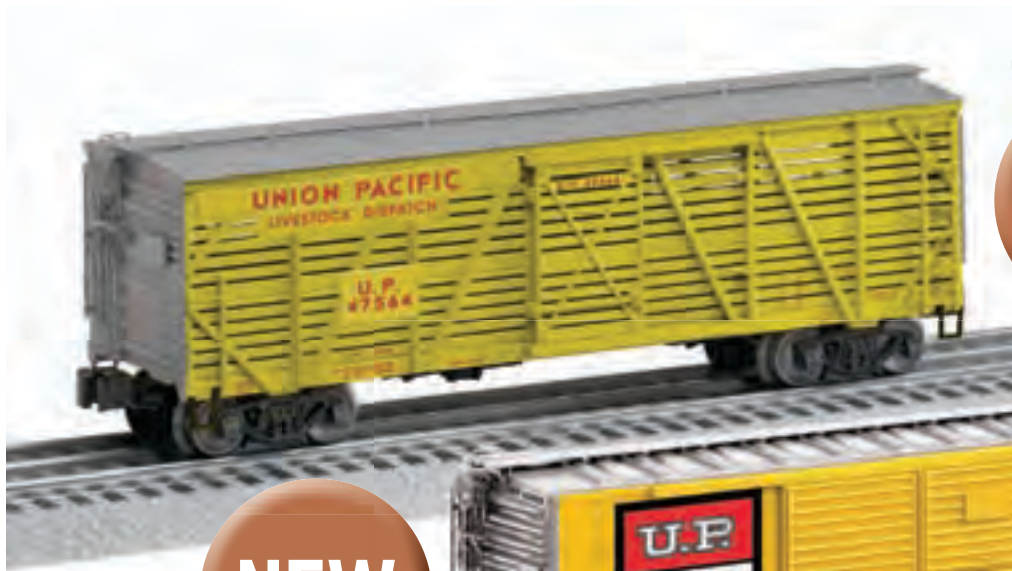

C

NEW

NEW



D



E



2-PACK

NEW



Prototypical curved ends on hopper

SCALE FREIGHT CARS

A, B. PS-4 FLATCARS WITH BULKHEADS

Newly-tooled bulkhead ends have been added to the Lionel PS-4 Flatcar, bringing a new prototypical look to this classic Pullman Standard freight car. Featuring a real wood on the vertical bulkhead sides as well as on the flatcar deck, this new flatcar adds a wider variety of realism to your scale layout. The flatcar also includes a load of six metal pipes with supports on the deck.

- Die-cast metal sprung trucks and operating couplers
- Hidden uncoupling tabs
- Real wood on flatcar deck and bulkhead inner sides
- Separately applied metal underframe details
- Load of six pipes with deck supports
- Minimum Curve: 0-36
- Length: 14 ¾"

A. 6-27838 Pennsylvania \$79.99

B. 6-27837 Boston & Maine \$79.99

C. BAKELITE PLASTICS PS-2 HOPPER

- Die-cast metal sprung trucks and operating couplers
- Rotating bearing caps
- Hidden uncoupling tabs
- Opening roof hatches
- Minimum Curve: 0-31
- Length: 10 ¼"

6-27059 \$69.99

D, E. 40' FLATCAR WITH METAL PIPES

- Die-cast metal sprung trucks and operating couplers
- Hidden uncoupling tabs
- Real wood deck
- Die-cast metal body
- Separately applied metal underframe details
- Includes load of six metal pipes with simulated straps
- Minimum Curve: 0-31
- Length: 11 ¼"

D. 6-27816 D&RGW \$79.99

E. 6-27824 Milwaukee Road \$79.99

F. PENN CENTRAL PS-2 HOPPER

- Die-cast metal sprung trucks and operating couplers
- Rotating bearing caps
- Hidden uncoupling tabs
- Die-cast metal body and frame
- Removable single-piece coal load
- Minimum Curve: 0-31
- Length: 12 ¾"

6-27424 \$79.99





NEW

C



D



E



NEW

F

FREIGHT CARS

A. WESTERN PACIFIC HERITAGE BOXCAR

With decoration inspired by Union Pacific's magnificent SD70ACe Heritage locomotives and Lionel's matching cabooses, this car is the perfect addition to your U.P. Heritage train consist.

- Die-cast metal sprung trucks and operating couplers
- Hidden uncoupling tabs and rotating bearing caps on trucks
- Separately applied metal underframe details on boxcar
- Opening doors
- Minimum Curve: 0-31
- Length: 16 1/2"

6-27254 \$84.99

B. UNION PACIFIC HUSKY STACK® 2-PACKS

- Die-cast metal sprung trucks and operating couplers
- Hidden uncoupling tabs and rotating bearing caps on trucks
- Die-cast metal body
- Each car includes two intermodal containers featuring opening doors
- Unique road number on each single car and container
- Minimum Curve: 0-31
- Length: 16 3/8" each

6-27707 \$224.99



A



B



NEW

3-PACK

Unique decorations
each side of cars



C



D



**C. BNSF WHALE-SCHEME BATHTUB GONDOLA
3-PACK**

True to the actual gondola on the BNSF rail line, Lionel offers modern BNSF "whale-scheme" decoration on three new Lionel bathtub gondolas. Featuring unique decoration on each side of the car, these bathtub gondolas also come equipped with rotary couplers.

- Die-cast metal trucks and operating couplers
- One dual rotary coupler car and two with single rotary coupler
- Unique road number on each car
- Minimum Curve: 0-31
- Length: 11 3/4"

6-27844 \$199.99

**D. CANADIAN NATIONAL BATHTUB GONDOLA
#193140**

- Die-cast metal trucks and operating couplers
- Dual rotary couplers
- New road number
- Minimum Curve: 0-31
- Length: 11 3/4"

6-27828 \$64.99



LIONMASTER LEGACY STEAM LOCOMOTIVES WITH VISION WHISTLE STEAM

The LionMaster series brings out the giants of steam to more modest size O Gauge layouts.

Here's your chance to get the legendary PRR T1 and U.P. Big Boy locomotives fully equipped with LEGACY, and at a scaled-down size that can negotiate even 0-31 curves. These detailed LionMaster engines maintain a correct sense of proportion and includes many separately applied details, such as accurate builder's plates.

T1 and Big Boy LionMaster steam locomotives are fully equipped with the best of LEGACY Command Control, LEGACY RailSounds, and Odyssey II Speed Control. And for the first time ever, they also feature the high realism of VISION Whistle Steam, a new steam effect that mimics blasts of steam that emanate from a real locomotive whistles when they're blown. The VISION Whistle Steam effect is synchronized to the RailSounds sound system.

- **LEGACY Control System** equipped – able to run in LEGACY Control mode, in TrainMaster Control mode, or in Conventional mode with a standard transformer
- **Odyssey II Speed Control** with On/Off switch
- **LEGACY RailSounds** sound system featuring:
 - CrewTalk dialog and TowerCom announcements, each with different scenarios depending on whether the locomotive is in motion or stopped
 - Six official railroad speeds with corresponding CrewTalk dialog
 - DynaChuff synchronized chuffing with 32 levels of intensity as the locomotive gains speed
 - LEGACY Real-Time Quilling Whistle control with instant response for realistic signature 'quilling' and correctly timed warning signals
 - Single hit or continuous bell sounds
- **Powerful maintenance-free motor** with momentum flywheel

- **VISION Whistle Steam** – Realistic smoke output from whistle when whistle is blown
 - Fan-driven smoke unit with adjustable smoke output delivers varying intensity of smoke to main stack and whistle
 - All steam effects are synchronized to the RailSounds sound system
- **Wireless Tether** connection between locomotive and tender
- **ElectroCoupler** on rear of tender
- **Dual powerful maintenance-free motors**
- **Directional lighting** including operating headlight and back-up light on rear of tender
- **Illuminated classification lights** on the front of locomotives
- **Traction tires**
- **Interior illumination** in cab
- **Die-cast metal locomotive body, pilot, and trucks**
- **Die-cast metal tender body and trucks**
- **Separately applied metal details**
- **Accurate, separately applied builder's plates**
- **Authentically detailed cab interior**
- **Glowing firebox** in T1 cab

- Flickering firebox in Big Boy cab
- Cab glass windows
- Engineer and fireman figures
- Minimum Curve: 0-31
- Length: T1 Duplex: 27" Big Boy: 29"

A. 6-11207 Pennsylvania T1 Duplex 4-4-4-4 **\$799.99**

B. 6-11208 Union Pacific Big Boy **\$899.99**





C

ALL ITEMS
NEW

C. PENNSYLVANIA ACF STOCK CAR

- Die-cast metal sprung trucks and operating couplers
- Hidden uncoupling tabs
- Die-cast metal frame
- Metal underframe details
- Opening doors
- Four hand-painted cattle figures included
- Minimum Curve: 0-31
- Length: 11 1/2"

6-27259 \$69.99

D. UNION PACIFIC CA-3 CABOOSE

First delivered in 1942, CA-3 class cabooses were the first steel-type cabooses to enter the Union Pacific fleet. They were the only U.P. class to be built with a distinctive running board on the cupola roof, and they also came equipped with grab handles placed vertically along the cupola ends. Close to 200 CA-3 cabooses were built for the Union Pacific in the 1940s, all painted in standard freight car red early in their career. Die-cast metal sprung Q-type trucks

- Hidden uncoupling tabs
- Separately applied metal underframe details

- Running boards on body roof and cupola roof
- Smoke with On/Off switch
- Detailed and decorated interior with figures
- Interior illumination
- Minimum Curve: 0-31
- Length: 10"

6-27633 \$94.99



A

B

LEGACY LIONMASTER FREIGHT SET

Ready-to-Run Set in New York Central Livery

NEW YORK CENTRAL LEGACY LIONMASTER DIESEL FREIGHT SET

The ready-to-run New York Central Diesel Freight set is ready for duty. Taking the lead, a modern behemoth – the LionMaster SD90 diesel locomotive complete with the LEGACY Control System, LEGACY RailSounds, and Odyssey II Speed Control – thunders down the mainline. Dressed in NYC's famous lighting stripe scheme, this powerful diesel pulls an impressive and colorful consist featuring modern, detailed freight equipment used on real railroads today. With a generous set of track and transformer, you have everything needed to run this special LEGACY-equipped set.

Set Includes

Lionmaster SD90MAC, I-beam flatcar, double-door boxcar, ACF 2-bay hopper, cylindrical hopper, Northeastern-style caboose, seven straight FasTrack track sections, 12 0-48 curved FasTrack track sections, a FasTrack terminal section, and CW-80 Transformer

Locomotive Features

- **LEGACY Control System** equipped – able to run in LEGACY Control mode, in Trainmaster Command Control mode, or in Conventional mode with a standard transformer
- **Odyssey II Speed Control** with On/Off switch

• LEGACY RailSounds sound system featuring:

- CrewTalk dialog and TowerCom announcements, each with different scenarios depending on whether the locomotive is in motion or stopped
- Five official railroad speeds with CrewTalk dialog
- Eight diesel RPM levels
- LEGACY "Real-Time Quilling Horn" control with instant response for realistic signature "quilling" and correctly timed warning signals
- Single hit or continuous mechanical bell sounds
- Directional lighting, including LED operating headlights and operating classification lights
- Front and rear **ElectroCouplers**
- Dual powerful maintenance-free motors with momentum flywheels
- Four traction tires
- Fan-driven smoke unit
- Die-cast metal trucks, pilots, fuel tank
- Metal frame
- Separately applied metal details
- Illuminated cab interior
- Engineer and fireman figures
- Length: 17 ½"

Rolling Stock Features

- Die-cast metal sprung trucks and operating couplers (caboose has die-cast metal trucks)
- Opening doors on boxcar
- Opening roof hatches on cylindrical hopper
- Interior illumination and operating smoke unit in caboose
- Separately applied metal details on caboose
- Individually boxed
- Minimum Curve: 0-31
- Each car in set individually boxed
- Length: Approx. 77"
- Layout Dimensions: 50" x 90"

6-31791 New York Central Lionmaster Diesel Freight Set **\$699.99**

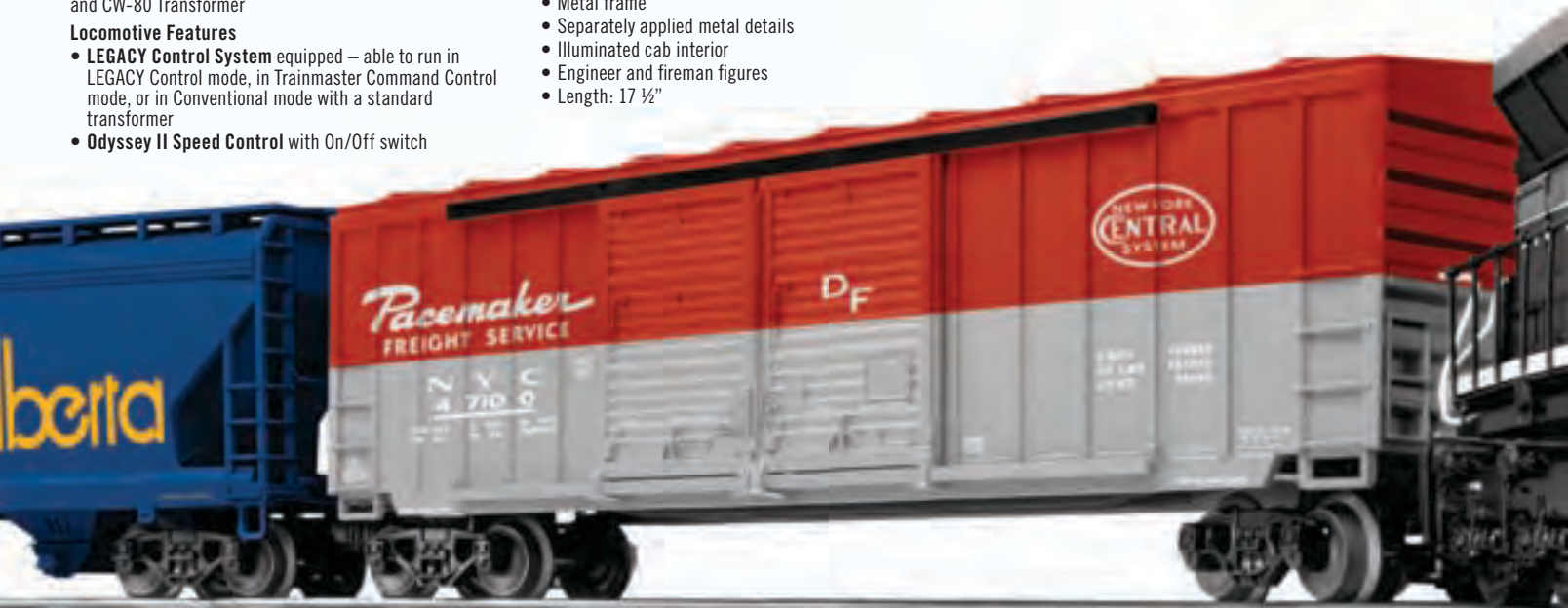

LIONMASTER



LEGACY
R.A.I.L.S.O.U.N.D.S



READY-
TO-RUN
SET

THE TEXAN SET

A. THE TEXAN READY-TO-RUN SET

Clear the tracks for a new freight boss in the West, the big Texan Set led by two FT diesels. Rugged, tough, and glamorous too, the FT units are dressed in the dazzling red scheme of the Texas Special. This hefty set also includes five colorful, star-studded freight cars including a quad hopper, tank car, boxcar, stock car, and caboose. In addition, this special ready-to-run set comes with a deluxe, Texas-size set of "Twice-Around" track and a powerful CW-80 Transformer.

Set Includes

One powered FT diesel, one non-powered FT diesel, boxcar, single-dome tank car, quad hopper, bi-level stock car, extended vision caboose

Also includes a CW-80 Transformer and a "Twice-Around" track pack that includes the following FasTrack sections: ten 0-36 45-degree curves, nine 10" straights, one terminal straight, nine 0-48 30-degree curves, one 5" straight, two 1 3/8" straights, one 1 3/4" straight, and one 45-degree crossover

FT A-Units Feature

- Die-cast metal trucks, pilot, fuel tank
- Operating couplers on both ends
- Metal frame

Powered FT A-Unit Also Features

- Transformer controlled forward, neutral, and reverse operation
- TrainSounds sound system with diesel engine revving, horn, bell, squealing brakes, and operator-controlled, multi-part dialog
- Operating headlight
- Dual powerful maintenance free motors
- Lighted cab interior
- Engineer and fireman figures
- Traction tires

Rolling Stock Features

- Die-cast metal sprung trucks and operating couplers
- Die-cast metal non-sprung trucks on caboose

- Opening doors and metal frame on boxcar and stockcar
- Metal handrails, platforms, and ladders on tank car
- Roof cover with opening hatches on hopper
- Metal frame on caboose
- Interior illumination and operating lantern lights on caboose

- Each car in set individually boxed
- Minimum Curve: 0-27
- Approx. Set Length: 78 1/2"
- Layout Dimension: Approx. 50" x 98"

6-30142 \$699.99

B. TEXAN FREIGHT ADD-ON 2-PACK

2-Pack Includes

- 6-37025 Moe and Joe Lumber Car
- 6-26634 Flatcar with Piggyback Trailers

Features

- Operating couplers
- Die-cast metal trucks (trucks are sprung on flatcar)
- Metal superstructure
- Moe & Joe flatcar features figures that unload real wood boards at the touch of a button (remote Control Track section required)
- Includes a trackside wood unloading bin
- Piggyback flatcar includes two removable trailers
- Individually boxed
- Minimum Curve: 0-27
- Length: 11" each

6-11173 \$129.99

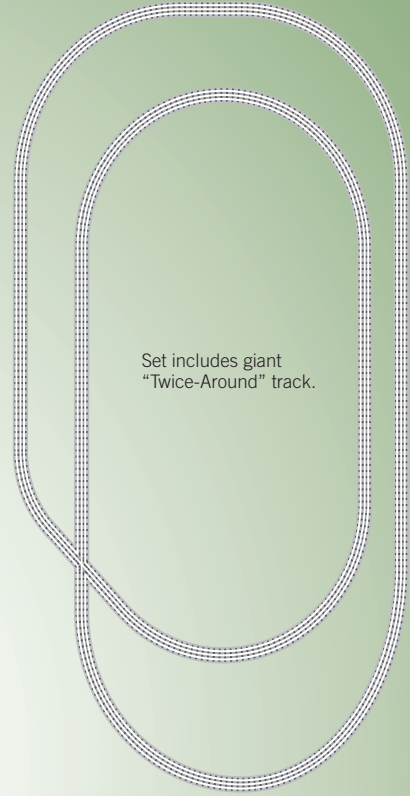

Set includes giant "Twice-Around" track.

ALL ITEMS
NEW

A



READY-TO-RUN SET



B
2-PACK



CANADIAN MAPLE LEAF FREIGHT WITH DIESEL EXHAUST



A. CANADIAN MAPLE LEAF FREIGHT

Running east through Canada then down along the great Mississippi, two rugged RS-3 diesels wearing the famous Maple Leaf herald haul loaded cars to their destination. Racing hard through the morning, a trail of diesel exhaust streams out of the roof stack on the leading engine. The trail of smoke is a handsome sight to see as the RS-3 freight train disappears into the landscape, and the faint sound of its distant horn is heard one last time.

Along with realistic TrainSounds and dual motor power, the powered RS-3 in this exciting new set comes equipped with all-new Diesel Exhaust. Enjoy this new diesel feature just as you've enjoyed steam engine smoke for so many years. In addition to the powered and non-powered engines, this ready-to-run train set also includes five colorful freight cars and enough FasTrack to make an extra long 40" x 70" layout.

A. Set Includes

Powered RS-3 diesel, non-powered RS-3 diesel, log car, boat loader car, boxcar, quad hopper, caboose, eight curve FasTrack sections, five straight FasTrack section, one FasTrack terminal section, powerful CW-80 Transformer

Both RS-3 Diesels Feature

- Die-cast metal trucks, pilot, fuel tank
- Operating couplers on both ends
- Metal frame

Powered RS-3 Also Features

- Transformer controlled forward, neutral, and reverse operation
- **DIESEL EXHAUST** smoke effect
- TrainSounds sound system with diesel engine revving, horn, bell, squealing brakes, and operator-controlled, multi-part dialog
- Operating headlights
- Front and rear operating couplers
- Dual powerful maintenance free motors
- Traction tires
- Lighted cab interior
- Engineer and fireman figures

Rolling Stock Features

- Die-cast metal sprung trucks and operating couplers
- Die-cast metal non-sprung trucks on caboose
- Opening doors and metal frame on boxcar
- Metal boat loader with four removable boats on flatcar deck
- Roof cover with opening hatches on hopper
- Metal chains and simulated wood log on flatcar
- Caboose has separately applied grab rails and interior illumination

- Each car in set individually boxed
- Minimum Curve: 0-27
- Set Length: Approx. 78 ½"
- Layout Dimension: 40" x 70"

6-30145 \$549.99

B. MAPLE LEAF ADD-ON 2-PACK

2-Pack Includes

- 6-26633 Flatcar with Engines
- 6-26431 ACF 2-Bay Hopper

Features

- Die-cast metal sprung trucks and operating couplers
- Flatcar includes load of two removable engine bodies with tie-down "chains"
- Minimum Curve: 0-27
- Length: Flatcar: 11"
Hopper: 9 ½"

6-11174 \$109.99



**ALL ITEMS
NEW**

READY-
TO-RUN
SET

DIESEL
EXHAUST



A



B

GREAT NORTHERN RAILWAY EMPIRE FREIGHT EXPRESS WITH WHISTLE STEAM

Something new is rounding the bend at breakneck speed. It's the original superpower, the famous Berkshire engine, now equipped with smoke deflecting "elephant ears" and a realistic Whistle Steam effect! From the flat Midwest to the mountainous West, and spanning the northernmost boundaries of the United States, the Great Northern Railway was truly an "Empire Builder".

A famous passenger railway, the Great Northern also hauled a wide variety of freight east and west, until the 1970s when it merged with BNSF. Equipped with RailSounds, smoke deflectors, and Whistle Steam, the Great Northern Berkshire and the classic string of colorful freight cars delivers more realism and fun to your layout.

Set Includes

RailSounds Berkshire, lighted bullion mint car, liquified tank car, and lighted caboose

Locomotive Features

- Transformer controlled forward, neutral, and reverse operation
- **RailSounds** sound system with steam sounds, synchronized chuffing, crew announcements, brake squeal, steam whistle, and bell
- Operating headlight
- Puffing stack smoke unit
- **VISION Whistle Steam** effect

- Smoke deflectors on sides of locomotive
- Operating coupler on rear of tender
- Powerful maintenance-free motor
- Traction tires
- Die-cast metal locomotive body and trucks
- Die-cast metal tender body and trucks with metal frame
- Engineer and fireman figures

Rolling Stock Features

- Die-cast metal sprung trucks and operating couplers
- Die-cast metal non-sprung trucks on caboose
- Interior light and plated bullion load in mint car
- Bulkhead ends and flatcar base on tankcar
- Metal frame on mint car and caboose
- Interior illumination in caboose
- Roof rail antennas and underside box on caboose

- Each car in set individually boxed
 - Minimum Curve: 0-27
 - Set Length: Approx. 48 1/4"
- 6-31799 \$429.99**



LIGHTED MINT
AND CABOOSE
INTERIORS

WHISTLE
STEAM
EFFECT

NEW



OPERATION EAGLE JUSTICE SET

A. OPERATION EAGLE JUSTICE SET

In modern urban camouflage, Operation Eagle is ready for extreme action against hostile forces if necessary. A GP7 diesel leads the entourage to a top-secret destination, specially-equipped with four camouflaged missiles strapped to its sides near the roof. Day and night, the Operation Eagle radar car scans the skies for infiltrators, while the fully-loaded missile firing car awaits special orders. Carefully and quickly, a highly volatile substance is transported in two armored containers on the deck of a flatcar, while the Operation Eagle security caboose guards the train from any tail-end attack.

In dramatic decoration, the Operation Eagle Special Forces Freight set offers a wide variety of action on your traditional layout. Each car in this special set includes an operating

feature, including the Chalmers-type car that fires missiles, a rotating antenna on the radar car, the illuminated searchlight on the security car, and lighted containers on the traditional flatcar. In addition, the conventional GP7 in this set comes equipped with a brand new, exciting feature—Diesel Exhaust. Watch the exhaust smoke stream from the diesel rooftop, similar to the puffing smoke feature on your Lionel steam engines.

Set Includes

GP-7 diesel, radioactive waste flatcar, radar car, missile firing car, security caboose

Locomotive Features

- Transformer controlled forward, neutral, and reverse operation

- TrainSounds sound system with diesel engine revving, horn, bell, squealing brakes, and operator-controlled, multi-part dialog
- **Diesel Exhaust** smoke
- Operating headlights
- Front and rear operating couplers
- Powerful maintenance free motor
- Metal frame
- 4 missiles strapped to sides of engine
- Die-cast metal trucks
- Traction tires
- Illumination in cab interior



ALL ITEMS
NEW





ROLLING STOCK FEATURES

- Die-cast metal trucks and operating couplers
- Eight removable missiles on Chalmers-type car can be "fired" off deck
- Blinking lights inside removable containers
- Metal plate on roof of flatcar containers allows them to be picked up by magnet
- Metal rails on flatcar deck
- Rotating antenna and illuminated radar screen on radar car
- Illuminated searchlight rotates via track power on security car
- Minimum Curve: 0-27
- Approx. Set Length: 57 3/4"

6-30144 \$499.99

B. OPERATION EAGLE ADD-ON 2-PACK

Add more camouflaged firepower to your Operation Eagle Set! Concealed inside the Minuteman Car, a missile is ready for launch. Give the order to launch with the press of a button and watch the missile fly out the open roof. Lift the helicopter off the flatcar deck and survey the terrain safely from the sky.

2-Pack Includes

- 6-26635 Flatcar with Helicopter
- 6-26431 Minuteman Car

Features

- Operating couplers
- Die-cast metal sprung trucks on flatcar
- Die-cast metal trucks on and stamped metal frame on minuteman car

- Removable helicopter on flatcar deck
- Missile inside minuteman car can be launched (Remote control track section is required)
- Minimum Curve: 0-27
- Length: Flatcar: 11"
Minuteman Car: 10 1/4"

6-11175 \$124.99

**DIESEL
EXHAUST
SMOKE**

**REMOVABLE
MISSILE ON
DIESEL**





PENNSYLVANIA GG-1 PASSENGER SET



BAG OF PELLETS
AND BAG OF
"NUCLEAR MATERIAL"
INCLUDED
IN SET



75
PRR GG-1
ANNIVERSARY



A. PENNSYLVANIA GG-1 PASSENGER SET

A classic Lionel set with timeless features, the Pennsylvania GG-1 Passenger Set is led by a conventional GG-1 electric locomotive equipped with legendary dual Pullmor motors. This powerful engine also features Magne-Traction, electronic horn and bell, manually operating pantographs, and is made of sturdy die-cast metal. GG-1 #4829 with feathered pinstripes pulls three tuscan Madison cars pin-striped in gold decoration. The City of Pittsburg coach, Times Square coach, and City of Chicago observation car all feature interior illumination and die-cast metal six-wheel trucks.

Set Includes

GG-1 locomotive, two coach cars, and one observation car

Locomotive Features

- Transformer controlled forward, neutral, and reverse operation
- Dual Pullmor motors
- Electronic horn and bell
- Directional headlights
- Die-cast metal body, pilots, and trucks
- Metal frame
- Electronic e-unit with Direction Lock
- Operating couplers
- Illuminated marker lenses
- Operating pantographs raise and lower manually
- Traction tires

- Powerful maintenance-free motor
- **Magne-Traction**

Madison Passenger Cars Feature

- Die-cast metal 6-wheel trucks
- Operating couplers
- Die-cast metal ends
- Metal frame
- Interior illumination
- Each car in set individually boxed
- Minimum Curve: 0-31
- Set Length: 57"

6-31790 \$499.99

AEC COLLECTION

B. AEC RADIOACTIVE TRANSPORT SET

Be careful! The AEC Radioactive Transport Set is ready to carefully move all hazardous radioactive materials to safe destinations on your layout. The specially decorated Atomic Energy Commission (AEC) burro crane pulls two AEC gondolas loaded with radioactive containers, raw steel material, and nuclear isotopic waste from a nearby nuclear reactor site to a disposal facility further down the tracks. As you can see by the glow-in-the-dark decoration on the cars, these radioactive loads must be handled carefully!

Set Includes

One burro crane, two gondolas, four radioactive containers, one bag of metal pellets, one bag of glow-in-the dark material

Burro Crane Features

- Forward and reverse operation
- Rotating cab
- Manually controlled boom and winch
- Powerful Pullmor motor
- Metal frame
- Glow-in-the-dark decoration

Gondolas Feature

- Die-cast metal trucks and operating couplers
- Glow-in-the-dark decoration on cars and load
- Two radioactive containers in each gondola
- One bag of metal pellets in one gondola
- Each car in set individually boxed
- Set Minimum Curve: 0-27
- Set Length: 25"

6-31774 \$259.99

C. AEC NUCLEAR REACTOR

Originally inspired by a background illustration in the 1958 Lionel catalog, the Nuclear Reactor is the perfect accessory to add to your AEC Radioactive Transport Set! A magnetized arm unloads metal pellet loads from a waiting car. (1) Once raised, the metal pellets are dropped and loaded into the reactor dome. (2) Once activated, the nuclear reactor bursts in reactor light and the metal load is seemingly "processed" within the nuclear reactor. (3) Glow-in-the-dark "isotopic" material can then be released from the nuclear dome, and exited down a chute into an awaiting freight car. (4)

- Die-cast crane arm
- Stamped metal base and upper dome
- Single can motor
- Detailed molded lower dome
- Remote or manual operation
- Interior sequential lighting
- Interior strobing LED
- Includes one bag of steel pellets
- Includes one bag of glow-in-the-dark "isotope" material
- New AEC decoration
- Dimensions: 15" x 12" x 8 1/2"

6-24294 \$299.99

D. AEC GLOW-IN-THE-DARK TANK CAR

- Die-cast metal trucks and operating couplers
- Metal handrails, platform, and ladders
- Minimum Curve: 0-27
- Length: 10"

6-29629 \$49.99



NEW! DIFFERENT!

THE “VIRGINIAN”

RECTIFIER-TYPE ELECTRIC

LOCOMOTIVE

WITH TOMMORROW'S FREIGHT...OUTFIT NO. 2505W

Never before so much newness packed into one train set! Here's the most modern of all electric powered locomotives – the rectifier that converts AC to DC for maximum efficiency. The locomotive features an operating pantograph, headlights on both ends, illuminated number boards, steel railings and detailed die-cast trucks and couplers. Magne-Traction, a resonant horn and bold “Virginian” graphics mark this remarkable locomotive as a must have for every up-to-date layout. Train measures 5 ft., 6 ¼ ins. long.

Set Includes

- No. 2329 “Virginian” Rectifier-Type Electric Locomotive
- No. 6805 Atomic Energy Disposal Car
- No. 6519 Allis Chalmers Car (dark orange version)
- No. 6800 Airplane Car
- No. 6464-500 Timken Boxcar
- No. 6357 Cupola Caboose

Rectifier Features

- Pullmor motor
- Electronic e-Unit with Direction Lock
- Electronic horn and bell with volume control
- Die-cast metal trucks and operating couplers
- Metal frame
- Interior light
- Operating headlight
- **Magne-Traction**
- Traction tires

Freight Cars Feature

- Operating Couplers
- Die-cast metal bar-end style trucks on atomic energy car and caboose
- Die-cast metal AAR-style trucks on Allis Chalmers car, flatcar, and boxcar
- Opening doors on boxcar
- Removable airplane with folding wings on flatcar
- Two glowing canisters on atomic energy car
- Interior illumination in caboose
- Window inserts and smokestack on caboose

6-38339 No. 2505W Virginian Rectifier Freight Set **\$469.99**





1958

NEW





NO. 1619W 1959 SANTA FE ALCO FREIGHT SET

Twin "A" Unit "Santa Fe" Diesel Outfit Rules the Rails

Imagine these two beautiful red and silver twin Alco "A" unit diesels racing down your rails. And just take a look at the trainload of fun... a helicopter, boat, and two bridge girders, all of which may be unloaded. Train measures 6 ft., 1 in. long.

Set Includes

- No. 218 Santa Fe Alco Powered A-unit
- No. 218 Santa Fe Alco Non-powered A-unit
- No. 6819 Flatcar with Helicopter
- No. 6802 Flatcar with two Girders
- No. 6801 Flatcar with Boat
- No. 6519 Allis Chalmers Car (light orange version)
- No. 6017 Santa Fe Cupola Caboose (grey version)

Both Alco A-units Feature

- Die-cast metal truck side frame
- Die-cast metal couplers
- Metal frame

Powered Alco A-unit Also Features

- Pullmor motor
- Electronic e-Unit with Direction Lock
- Electronic horn and bell with volume control
- Operating headlight
- **Magne-Traction**
- Traction tires

Freight Cars Feature

- Operating couplers
- Die-cast metal AAR-style trucks
- Removable speed boat on #6801 flatcar
- Removable girders on #6802 flatcar
- Removable whirly-bird™ helicopter on #6819 flatcar
- Interior illumination in caboose
- Upgraded window inserts and smokestack on caboose

6-38342 1619W Santa Fe Alco Freight Set **\$469.99**



NEW



1959



1587S STEAM SET FOR GIRLS

in fashion-right colors...with cars to match. Now She Can Do Anything He Can Do...With Lionel's Exclusive Pastel Train Set For Girls! Girl railroaders all over the country are in love with this exclusive Lionel set. There's a beautiful frosted pink locomotive and tender with a matching NYC gondola with four white canisters, a robin's egg blue NYC boxcar, a buttercup yellow MKT boxcar, a lilac LV hopper car plus a sky blue PRR illuminated porthole caboose.

Set Includes

- No. 2037-500LT 2-6-4 Steam Locomotive
- No. 6436-500 Lehigh Valley Quad Hopper
- No. 6464-510 NYC Boxcar
- No. 6464-515 M-K-T Boxcar
- No. 6462-500 Gondola
- No. 6427-500 Pennsylvania Porthole Caboose

Locomotive Features

- Pullmor motor
- Die-cast metal body and chassis
- Die-cast metal trucks with operating coupler on rear of tender
- **Magne-Traction**
- Electronic e-unit with Direction Lock
- Electronic whistle and bell
- Operating headlight and green jewel marker lights

- Ornamental bell
- Puffing smoke is synchronized with the movement of the driving wheels
- Traction tires

Freight Cars Feature

- Bar-end style metal trucks with operating couplers
- Gondola includes four canisters
- Hopper includes removable coal load
- Interior illumination in caboose

6-38340 Girl's Set **\$579.99**





1957



NEW

PUFF SMOKE
Just like real locomotives,
your steam loco puffs real
as-life smoke.



NO. 2261W FREIGHT HAULER STEAM SET

Power-and then Some! A Huge Heavy-Duty 14-Wheeler with White Puffing Smoke, Bell and Whistle, and MAGNE-TRACTION



NO. 2261W FREIGHT HAULER STEAM SET

This one has super power, rugged look, absolute detail accuracy! A full 20 ½ inches from cowcatcher to ladder at rear of tender, she moves on extra large steel driving wheels driven by a powerful motor and, of course, also boasts MAGNE-TRACTION.

Here are just a few of the body details: die-cast "Baker" valve gear; piping and generator housing; interior cab details; bright, stainless steel handrails; metal ornamental bell and whistle.

Set Includes

- No. 646 4-6-4 steam locomotive
- No. 2046W tender
- No. 3562-50 Operating Barrel Car
- No. 6414 Evans Auto Loader
- No. 6436-25 Lehigh Valley Quad Hopper
- No. 6376 Circus Car
- No. 6417 Pennsylvania Porthole Caboose

This loco has all the elements that make steam power exciting!

- Pullmor motor
- Die-cast metal body, chassis
- Die-cast metal trucks with operating coupler on rear of tender
- **Magne-Traction**
- Electronic e-unit with Direction Lock

- Electronic whistle and bell
- Operating headlight and green classification lights
- Puffing smoke is synchronized with the movement of the driving wheels
- Traction tires
- Authentic eccentric rod and side rod action

Freight Cars Feature

- Bar-end style metal trucks with operating couplers
- Auto loader includes four removable autos
- Barrel car includes six wooden barrels and unloading bin
- Circus car features opening doors
- Hopper includes removable coal load
- Interior illumination in caboose

6-38329 No. 2261W Freight Hauler Steam Set **\$609.99**



1956





NO. 2507W NEW HAVEN F3 DIESEL FREIGHT SET

Past gates and banjo signals streaks the New Haven checkerboard... outfit no. 2507W New Haven F3 Diesel Freight Set. Two unit diesel in 1958's checkerboard markings with horn, headlight, Magne-Traction! Animated gondola! Auto cars!

A. NO. 2507W NEW HAVEN F3 DIESEL FREIGHT SET

Here's 1958 model railroading at its very best... in design, in color, in power! Only Lionel could build a loco so powerfully real, because only Lionel has powerful Magne-Traction! Adventure is featured in this exciting train set, as a railroad sleuth pursues a hobo 'round the cargo of the gondola car. And look at those factory-fresh autos on the flat car! You can take them right off and load them into the automobile boxcar behind. Train measure 6 ft., 4 ins. long.

Set Includes

- No. 2242P New Haven Powered F3 A unit
- No. 2242C New Haven Non-powered F3 B unit
- No. 3444 Animated Gondola Car
- No. 6464-425 New Haven Boxcar
- No. 6424 Twin Auto Car
- No. 6468 New Haven Automobile Car
- No. 6357 Illuminated Caboose

Powered F3 A-unit Features

- Die-cast metal pilot and frame
- Die-cast metal trucks with operating couplers
- Two Pullmor motors
- Magne-Traction
- Electronic e-unit with Direction Lock
- Electronic horn and bell with volume control
- Operating headlight
- Illuminated number boards and cab interior
- Traction tires

Non-powered B-unit Features

- Die-cast metal pilot and frame
- Die-cast metal trucks with operating couplers

Freight Cars Feature

- Operating couplers
- Bar-end style metal trucks on double-door boxcar and caboose
- Die-cast AAR-style trucks on flatcar and single-door boxcar
- Opening doors on boxcars
- Flatcar includes two removable autos
- Interior illumination in caboose
- Policeman chases hobo on animated gondola

6-38324 2507W New Haven F3 Freight Set \$599.99

B. ARCHIVE COLLECTION NEW HAVEN F3 A-A DIESEL SET

Decorated in classic McGinnis black and orange! Never produced, this F3 set is assigned No. 2342

Set Includes

- No. 2342P New Haven Powered F3 A-unit
- No. 2342T New Haven Non-powered F3 A-unit

Features

- Powered F3 A-unit has the same great features as the F3 A-unit in set.
- Non-powered A-unit features die-cast metal trucks and operating couplers

6-34559 Archive McGinnis New Haven F3 A-A set \$499.99





1958

B



SANTA FE FT WITH RAILSOUNDS

Built by General Motors' Electro-Motive Division, the FT diesel locomotive took its place next to its famous cousin the F3 as one of the great workhorses of the American rails. Now available with RailSounds in the classic Warbonnet scheme, you can add additional dual-motor power and upgraded sounds to your existing Santa Fe set. Or build up a new consist with the non-powered A-unit, B-unit, and Warbonnet caboose that are also available.

A. SANTA FE FT DIESEL WITH RAILSOUNDS

- Transformer controlled forward, neutral, and reverse operation
- RailSounds sound system with CrewTalk dialog
- Operating headlight
- Operating coupler on both ends
- Dual powerful maintenance-free motors
- Traction tires
- Die-cast metal trucks, pilot, fuel tank
- Metal frame
- Lighted cab interior
- Engineer and fireman figures
- Minimum Curve: 0-27
- Length: 12 3/4"

6-38215 \$279.99

B. SANTA FE NON-POWERED FT A UNIT

- Die-cast metal trucks, pilot, fuel tank
- Metal frame
- Engineer and fireman figures
- Minimum Curve: 0-27
- Length: 12 3/4"

6-28905 \$119.99

C. SANTA FE WARBONNET BAY WINDOW CABOOSE

- Die-cast metal trucks and operating couplers
- Interior lighting
- Flashing rear strobe light
- Metal frame
- Minimum Curve: 0-27
- Length: 10 1/4"

6-29737 \$69.99

D. SANTA FE FT NON-POWERED FT B UNIT

- Die-cast metal trucks, pilot, fuel tank
- Metal frame

6-38204 \$119.99





MONOPOLY

A. MONOPOLY HUDSON STEAM LOCOMOTIVE

Pull your growing line of Monopoly-series freight cars with this Hudson locomotive dressed in commemorative Monopoly decoration!

- Transformer controlled forward, neutral, and reverse operation
- TrainSounds sounds system
- Operating headlight
- Operating coupler on rear of tender
- Powerful maintenance-free motor with momentum flywheel
- Traction tires
- Puffing smoke unit
- Manually adjustable volume control
- Die-cast metal locomotive and tender body, metal frame and trucks
- Minimum Curve: 0-27
- Length: 18 ¾"

6-38678 \$239.99

B. MONOPOLY BOXCAR 3-PACK #4

The fourth installment of the popular Monopoly boxcar series by Lionel is here for 2010. Featured in this new pack are Park Place, St. Charles Place, and Oriental Avenue.

3-Pack Includes

- 6-39331 Oriental Ave
- 6-39329 Park Place
- 6-39330 St. Charles Place

Features

- Die-cast metal sprung trucks and opening couplers
- Metal frame
- Opening doors
- Minimum Curve 0-27
- Length: 10 ½"

6-39328 \$164.99

C. MONOPOLY "GO TO JAIL" MINT CAR

Go directly to jail — do not pass go, do not collect \$200! A great dedication from one of America's favorite past-times to another.

- Die-cast metal sprung trucks and operating couplers
- Minimum Curve: 0-27
- Length: 10 ¼"

6-29635 \$69.99

© 2010 Hasbro. All rights reserved.



M-497 JET-POWERED RAIL CAR

D. NEW YORK CENTRAL M-497 LOCOMOTIVE

Dubbed the "Black Beetle", the M-497 jet-powered rail car was one of the most unique experiments in American railroad history. In the mid 1960s, the U.S. Dept. of Commerce began to seriously study high speed rail as a viable method of commuter transportation in the Northeast. New York Central Railroad at the time was also interested in replacing its traditional long-distance passenger service, and considered with modern 200-mph high speed routes. Ultimately, NYC's research laboratory in Cleveland, Ohio worked on the idea and purchased surplus B-36 bomber jet engines which were mounted onto the roof of a standard RDC passenger car. The front of the car was modified, too, with a dramatic streamlined nose painted black.

In July of 1966, M-497 tests were conducted on New York Central's longest stretch of straight track. The results were amazing with the "Black Beetle" hitting a new

American rail speed record of 183 miles per hour. Experiments continued over the week and allegedly the jet rail car reached even faster speeds. After the experiments, the M-497 was dismantled and the RDC commuter car returned to regular service. The jet engines, too, were reused, finding new life in New York Central's jet snowblower cars.

Lionel now offers the NYC M-497 Jet Powered Rail Car in the 2010 lineup. Complete with streamlined cowl on the front end and the eye-catching jet engine pod on the roof, the new jet-powered rail car is a strikingly unique car to add to your layout. This rail car comes equipped with a Pullmor motor, headlight, and interior lighting. You'll also hear the roar of jet engine sounds and "red hot" illumination from the back of the jets.

- Transformer controlled forward, neutral, and reverse operation
- Electronic e-unit with direction lock
- Realistic jet engine sounds
- Horn and bell sounds
- Simulated jet engine mounted on roof with illumination
- Pullmor motor
- Operating headlight
- Operating coupler on rear
- Marker lights
- Interior light
- Magne-Traction
- Traction tires
- Metal frame
- On/Off sound switch
- Volume control
- Minimum Curve 0-36
- Approximate Length: 18"

6-38401 \$299.99



NEW

3-PACK



B



C

JET ENGINE SOUND

JET ENGINE ILLUMINATION



D

NEW



WHITE PASS & YUKON



Completed in 1900 at the time of the Klondike Gold Rush, the White Pass & Yukon Railway was built under the harshest conditions through the coastal mountains of Alaska. Today, the "railway built of gold" is an International Historic Civil Engineering Landmark and operates currently as Alaska's most popular passenger shore excursion.

- Traction tires
 - Interior illumination
 - Dynamic brake superstructure on roof
 - Minimum Curve: 0-27
 - Length: 12"
- 6-28594 \$299.99**

- Die-cast metal sprung trucks and operating couplers
 - Opening doors on reefer
 - Metal handrails, platform, and ladders on tank car
 - Removable trailer/trailer with flatcar
- 6-31793 \$194.99**

A. WHITE PASS NW-2 SWITCHER

- Transformer controlled forward, neutral, and reverse operation
- Directional lighting
- Electronic diesel horn and bell
- **Magne-Traction**
- Die-cast metal trucks
- Operating couplers
- Pullmor motor
- Metal frame



B. WHITE PASS & YUKON ADD-ON 3-PACK

Expand your Alaskan layout with three new White Pass & Yukon freight cars

3-Pack Includes

Tank car, wood-sided reefer, flatcar with tractor and trailer

C. WHITE PASS EXTENDED VISION CABOOSE

- Die-cast metal trucks with operating couplers
- Metal frame
- Interior illumination
- Operating lantern lights
- Minimum Curve: 0-27
- Length: 10 1/4"

6-29733 \$89.99





3-PACK

PENNSYLVANIA ALCO A-A SET

Modeled after ALCO's FA, this classic locomotive makes its return to the Lionel main line. Decorated in stunning Pennsylvania tuscan and five-stripe gold, it's the perfect diesel pair to pull the matching 4-pack of streamliner passenger cars.



- Pullmor motor
 - Electronic horn and bell
 - Operating headlight
 - **Magne-Traction**
 - Length: 10 3/4" each A unit
 - Minimum Curve: 0-27
- 6-38210 \$399.99**

E. PENNSYLVANIA STREAMLINER 4-PACK

- Set Includes**
 Baggage car, coach, vista dome, observation car
- Die-cast metal six-wheel trucks
 - Operating couplers
 - Interior illumination except baggage car
 - Decorated interiors
 - Vinyl diaphragms between cars
 - Opening doors
 - Minimum Curve 0-27
 - Set Length: 53"
- 6-35193 \$249.99**

D. PENNSYLVANIA ALCO A-A SET

Set Includes
 One powered and one non-powered Alco A unit

Both Units Feature

- Die-cast metal trucks
- Metal frame

Powered A Unit Also Features

- **Command Control**-equipped — able to run in Command Control Mode or in Conventional Transformer Control Mode

Sowing the Nation



Route of the West Express

COCA-COLA®

Explore the refreshing world of Coca-Cola with three exciting new cars by Lionel. Each colorful car is branded with authentic designs authorized by the Coca-Cola Company. It's the Real Thing!

A. COCA-COLA QUAD HOPPER

- Die-cast metal sprung trucks and operating couplers
 - Hopper roof cover with opening hatches
 - Minimum Curve: 0-27
 - Length: 11 ¾"
- 6-19365 \$59.99

B. COCA-COLA TROLLEY

- Bumper controlled forward and reverse operation
 - Operating LED headlights
 - Interior lighting
 - Powerful maintenance-free motor
 - Traction tire
 - Minimum Curve: 0-27
 - Length: 6 ¾"
- 6-28456 \$89.99

C. COCA-COLA TANK CAR

- Die-cast metal sprung trucks and operating couplers
 - Metal handrails, platform, and ladders
 - Minimum Curve: 0-27
 - Length: 10"
- 6-29640 \$54.99



TM & ©THE COCA-COLA COMPANY 2010

THE HERSHEY COMPANY



©2010 THE HERSHEY COMPANY. The HERSHEY'S, REESE'S, AND TWIZZLERS trademarks and trade dress are used under license.



B



C



THE HERSHEY COMPANY

With a history lasting over a hundred years, The Hershey Company has grown to include some of the most well known brands in the world. Sweeten your train layout with these three new colorful and collectible freight cars spotlighting The Hershey Company, including a Twizzlers hopper, a Hershey's reefer, and a Reese's vat car.

D. HERSHEY'S® CHOCOLATE WOOD-SIDED REEFER

- Die-cast metal sprung trucks and operating couplers
- Opening doors
- Minimum Curve: 0-27
- Length: 11"

6-19587 \$54.99



E

E. REESE'S® VAT CAR

- Die-cast metal sprung trucks and operating couplers
- Minimum Curve: 0-27
- Length: 11 ¼"

6-39488 \$59.99



F

F. TWIZZLERS® QUAD HOPPER

- Die-cast metal sprung trucks and operating couplers
- Hopper roof with opening hatches
- Minimum Curve: 0-27
- Length: 11 ¾"

6-19361 \$54.99

LIONEL CLASSIC BOXCARS



LIONEL ART BOXCAR 2-PACK

Celebrating some of the most memorable train art ever, the Lionel Art Boxcar Series continues with this 2010 two-pack. A handsome Santa Fe railroad art boxcar and a 1965 Lionel catalog art boxcar are included in this set.

- Die-cast metal sprung trucks and operating couplers
- Metal frame
- Individual box for each car
- Opening doors
- Minimum Curve: 0-27
- Length: 10 1/2" each

6-29965 \$115.99





2-PACK

NEW

WOOD-SIDED REEFER 2-PACK

- Die-cast metal sprung trucks and operating couplers
- Die-cast metal arch-bar style trucks
- Opening doors
- Individual box for each car
- Minimum Curve: 0-27
- Length: 11"

6-19590 \$109.99

2-PACK



MEET THE BEATLES! BOXCAR 2-PACK

The lads from Liverpool are making their premiere appearance with this new 2-pack of boxcars featuring cover art and playlists from The Beatles' first two Albums: Meet The Beatles and The Beatles' Second Album.

- Die-cast metal sprung trucks and operating couplers
- Metal frame
- Individual box for each car
- Opening doors
- Minimum Curve: 0-27
- Length: 10 1/2" each

6-29961 \$129.99

©2010 Apple Corps Ltd. A Beatles Product.



CSX MERGER WORK FREIGHT

CSX is on the move clearing brush, debris, weeds, and fallen trees on your layout. Colorful and original, all of these work freight cars are decorated in merger railroad names including Chessie, P&LE, Western Maryland, B&O, and Seaboard. Look closely and you'll find a variety of colorful graffiti on the gondola and hopper cars, a generator and worker figure with hose on the "weed killer" chemical tank car, and a searchlight and strobe light on the research car!



2-PACK

CSX FREIGHT 2-PACK #1

2-Pack Includes

- 6-39483 Gondola
- 6-29897 Research Car

Features

- Die-cast metal sprung trucks on gondola
- Die-cast non-sprung metal trucks on security car
- Operating couplers
- Illuminated searchlight rotates via track power on research car
- Operating red strobe light on roof of research car
- Minimum Curve: 0-27
- Length: Research Car: 11"
Gondola: 10"

6-11166 \$129.99

2-PACK

CSX FREIGHT 2-PACK #2

2-Pack Includes

- 6-27283 Tank Car
- 6-27431 Quad Hopper

Features

- Die-cast metal sprung trucks and operating couplers
- Generator and figure with hose on tank car deck
- Metal handrails, platform, and ladders on tank car
- Minimum Curve: 0-27
- Length: Hopper: 11 3/4" Tank car: 10"

6-11167 \$104.99



2-PACK

CSX FREIGHT 2-PACK #3

2-Pack Includes

- 6-39482 Maintenance Car
- 6-27822 Flatcar with Bulldozer

Features

- Die-cast metal sprung trucks and operating couplers
- Removable bulldozer on flatcar deck
- Two figures on maintenance car
- Minimum Curve: 0-27
- Length: 10"

6-11168 \$129.99

ROLLING STOCK

A. NEW HAVEN AUTOMOBILE BOXCAR

The return of a classic, the collectible 6468-style boxcar is now decorated in New Haven livery.

- Die-cast metal sprung trucks and operating couplers
- Stamped metal frame
- Opening double doors
- Minimum Curve: 0-31
- Length: 11 ¼"

6-39316 \$59.99

A



B. CP RAIL 6565 BOXCAR

This 6565 boxcar features the legendary look of the 6464 boxcars with the added heft of a die-cast metal frame.

- Die-cast metal sprung trucks and operating couplers
- Die-cast metal frame
- Opening doors
- Minimum Curve: 0-27
- Length: 10 ¼"

6-39308 \$54.99

B



C. GRANNY SMITH APPLES WOOD-SIDED REEFER

For the best apple pies, you can always count on Granny! This colorful reefer travels straight from the apple orchards to your town.

- Operating couplers
- Opening doors
- Minimum Curve: 0-27
- Length: 11"

6-19578 \$52.99

C



D. COCOA MARSH VAT CAR

The famous chocolate syrup with the lovable lion is back!

- Die-cast metal sprung trucks and operating couplers
- Metal frame
- Minimum Curve: 0-27
- Length: 11 ¼"

6-39484 \$59.99



E. TUPELO MILK CAR

Milk fit for a king!

- Die-cast metal sprung trucks and operating couplers
- Detailed molded frame and body
- Minimum Curve: 0-27
- Length: 8 ⅞"

6-26614 \$59.99



F. KREY'S REEFER

A colorful new reefer with a metal control panel that slides open on the side.

- Die-cast metal sprung trucks and operating couplers
- Opening doors
- Sliding metal door reveals control panel
- Minimum Curve: 0-27
- Length: 11 ¼"

6-19577 \$59.99



NEW

OPERATING CARS



A. NORFOLK SOUTHERN TRANSPARENT INSTRUCTION CAR

Transparent boxcars were used to demonstrate the destruction that could occur from improper boxcar loading or excessive coupling speeds. They were also used to test different loading methods to help reduce freight damage. With transparent sides, your own yard crew can examine the four interior pallet loads from the outside of the car!

- Die-cast metal trucks and operating couplers
- Interior illumination
- Transparent sides and opening doors
- Load of four removable pallet loads, including 12 boxes, four highway barrels, four oil drums, and a stack of lumber
- Minimum Curve: 0-27
- Length: 11 1/8"

6-19585 \$74.99



B. ALASKA RAILROAD HUSKY TRANSPORT CAR

The Alaskan Huskies need a rest after some grueling months leading the dog sled to safety. After loading them carefully in their crates, the trainer feeds the Husky dogs and shuts the boxcar door.

- Die-cast metal trucks and operating couplers
- Interior illumination
- Transparent sides and opening doors
- Six decorated dog crate box loads
- Figure in doorway
- Simulated husky dogs in interior
- Minimum Curve: 0-27
- Length: 11 1/8"

6-19586 \$74.99



See huskies inside!



C. KOI FISH AQUARIUM CAR

The colorful and peaceful Koi fish of Japan have made it safely to the states, and now are carefully transported throughout the country. Soon they will be at home in the tranquil waters of Koi fish ponds everywhere, and will fascinate onlookers endlessly with their dramatic palette of colors.

- Koi-fish decoration on circling interior belt appear to swim inside car
- Die-cast metal trucks and operating couplers
- Powerful maintenance-free motor with On/Off switch
- Interior illumination
- Minimum Curve: 0-27
- Length: 10 1/2"

6-36880 \$74.99





D

D. OPERATING PLUTONIUM CARS 2-PACK

Large stockpiles of plutonium waste extracted from dismantled nuclear weapons must be moved immediately! The radioactive waste containers will be stored safely in the Yucca Mountain Repository in Nevada. Use the Lionel Plutonium Waste Car to transport your nuclear waste to the Repository tunnel. Equipped with a magnet on the end of the hook, unload the plutonium waste containers with the boom car. A worker in a hazmat suit is overlooking the activities to make sure the materials are handled safely.

2-Pack Includes

- 6-37016 Radioactive Plutonium Flatcar
- 6-37017 Plutonium Boom Car

Features

- Die-cast metal trucks and operating couplers
- Manually operating boom on boom car
- Magnet on end of boom hook can pick up flatcar containers
- Magnetized removable figure in safety hazard suit on boom car deck



- Flatcar includes two removable containers that can be picked up by boom car magnet
- Blinking "plutonium" lights in flatcar containers
- Minimum Curve: 0-27
- Length: 11" each

6-37002 \$139.99



D

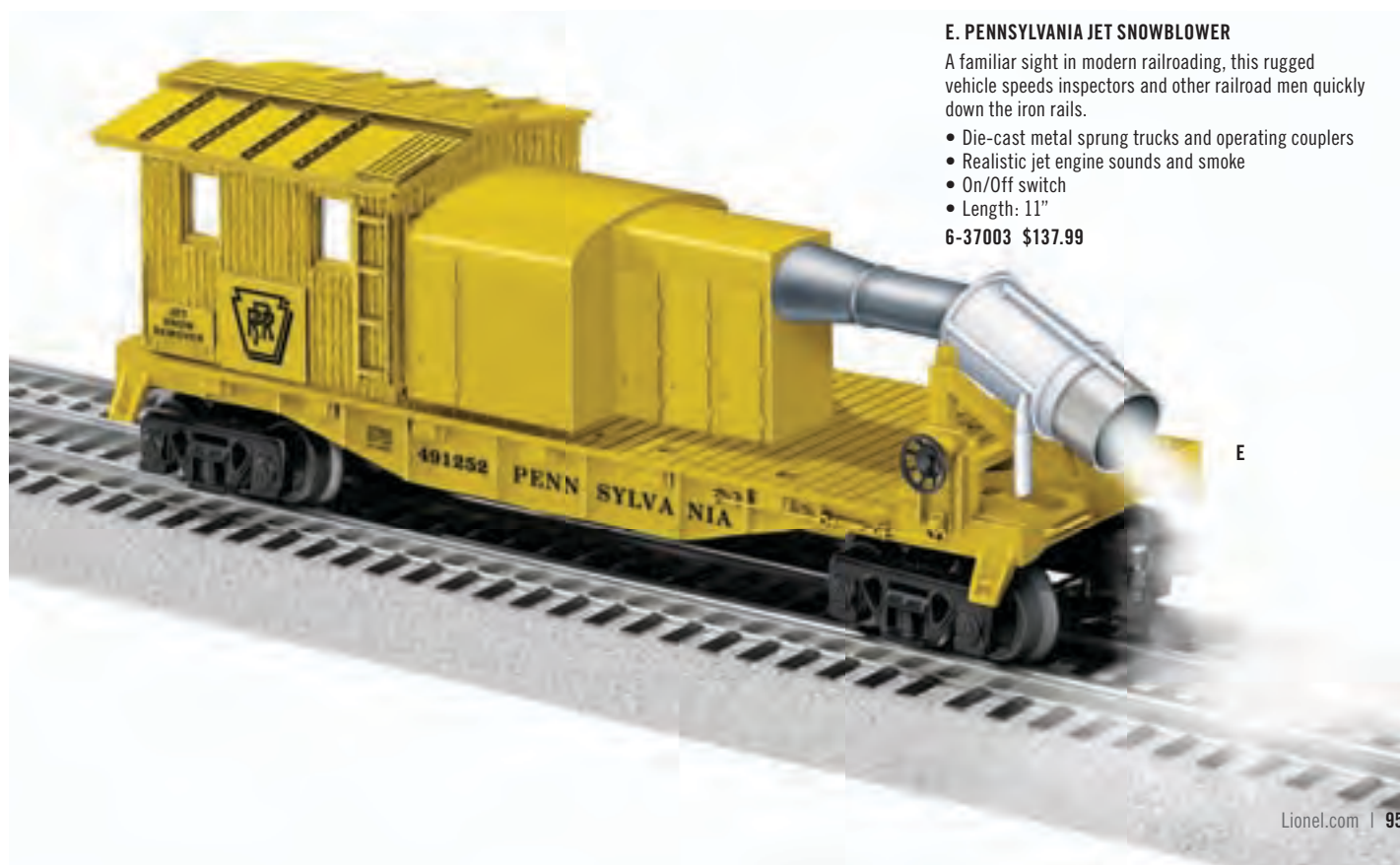

E. PENNSYLVANIA JET SNOWBLOWER

A familiar sight in modern railroading, this rugged vehicle speeds inspectors and other railroad men quickly down the iron rails.

- Die-cast metal sprung trucks and operating couplers
- Realistic jet engine sounds and smoke
- On/Off switch
- Length: 11"

6-37003 \$137.99

E

OPERATING CARS

A. MOUNT ST. HELENS SMOKING BOXCAR

Experience the most extreme hot sauce ever offered on the market! Mount St. Helens' Hot Sauce is as hot as a volcano eruption, and guaranteed to set your tongue on fire. Even the company's official boxcar is smoking at the seams as they mix secret ingredients for a new batch of the fiery concoction.

- Smoke wafts out opening door
- Flickering interior light simulates flaming fire
- On/Off switch
- Metal frame
- Minimum Curve: 0-31

- Length: 10 1/2"
- 6-37009 \$124.99

B. GREAT NORTHERN JUMPING HOBO BOXCAR

- Die-cast metal sprung trucks
- Opening doors
- Two figures
- FasTrack track system compatible
- Length: 10 1/4"

- 6-37012 \$74.99

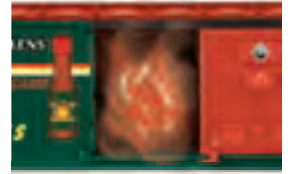

A



B



ACCESSORIES

Celebrate the Diamond Anniversary of the Gateman accessory!

C. 75TH ANIVERSARY GATEMAN

Join in the jubilation – the diamond anniversary for 75 years of the LIONEL Gateman accessory. Dressed up and ready to celebrate, this tried and true presence on your layout is still as enjoyable today as it was all those many years ago.

- Diamond shaped lantern
- Unique anniversary paint scheme and sign
- Special gold-plated finish

- 153C Contactor included for operation with 0-27 and 0 gauge tubular track
- FasTrack compatible with accessory activator track section (not included)
- Dimensions: 7" x 5 3/4" x 4 3/4"

6-16897 \$69.99

D. #133 PASSENGER STATION

Dressed in new colors, this classic lighted passenger station is perfect for any 0 or 0-27 gauge layout.

- Lighted interior
- Dimensions: 12 1/8" x 8 1/4" x 6 1/2"

6-14257 \$54.99



DIAMOND
LANTERN

GOLD
PLATED

C

75TH
ANNIVERSARY

NEW



D

TRACKSIDE

A
B

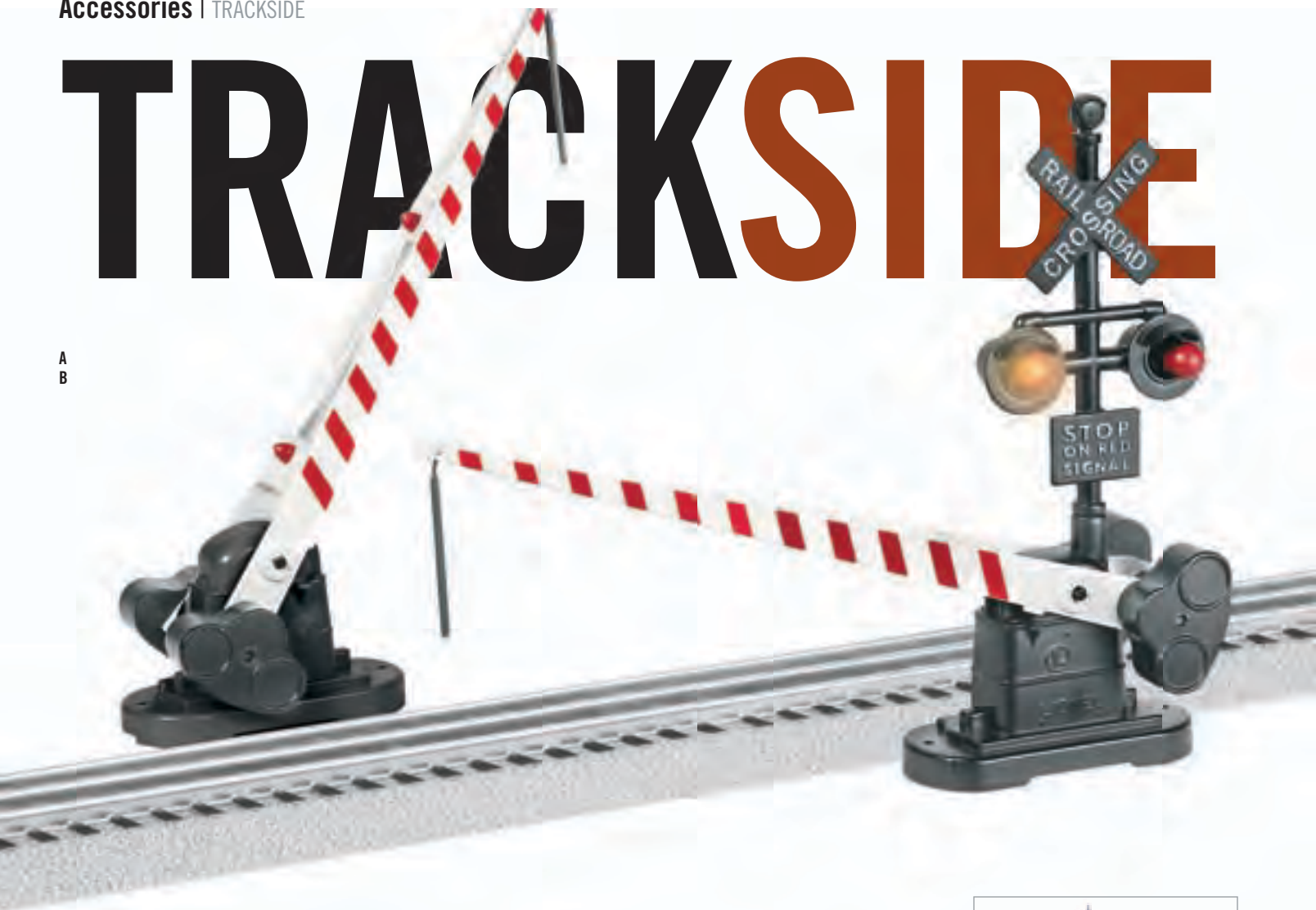

A. AUTO CROSSING GATE

- Gate drops when train passes by
 - 153C Contactor included
 - Also works with insulated track section (Sold separately)
 - Dimensions: 9 1/2" gate length
- 6-12714 \$49.99

B. AUTO CROSSING GATE AND SIGNAL

- Gate drops and lights illuminate when train passes by
 - 153C Contactor included
 - Also works with insulated track section (Sold separately)
 - Dimensions: 7 3/4" x 8 3/4" x 9 1/2"
- 6-62162 \$59.99

C. MAINLINE AUTO CROSSING GATES

- Die-cast metal construction
 - Red flashing signal
 - Gate drops when train passes by
 - Set of two
 - 153C Contactor included
 - Also works with insulated track section (Sold separately)
 - Dimensions: 4" x 1" x 4 1/2"
- 6-14098 \$99.99

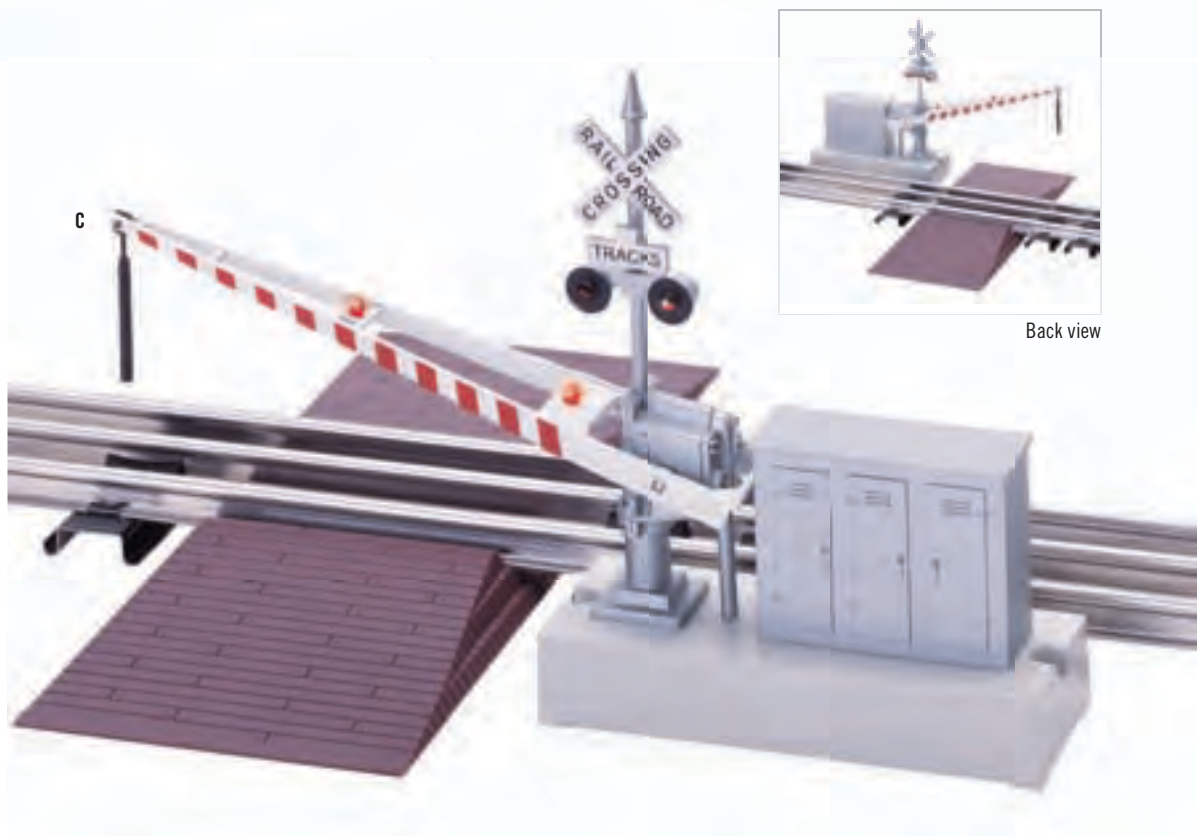

Back view

D. RAILROAD BUMPERS

- Easily snaps into place between outside rails of traditional O and O-27 track
- Set of three
- Dimensions: 3" x 1 1/2" x 1 1/2"

6-12717 \$7.49



E. #260 ILLUMINATED BUMPERS

- Easily snaps between outside rails of traditional O and O-27 track
- Illuminated red lights
- Set of two
- Dimensions: 3" x 1 1/2" x 1 1/2"

6-12715 \$12.99



F. DIE-CAST METAL BUMPERS

- Die-cast metal construction
- Illuminated red lights
- Easily snaps into place between outside rails of traditional O and O-27 track
- Set of two
- Dimensions: 3" x 1 1/8" x 2"

6-62283 \$26.99



G. 153IR CONTROLLER

- Die-cast metal structure
- Infrared sensors detect passing trains and activate connected accessories
- Time delay adjustment knob (From 0 to 5 seconds)
- Dimensions: 5" x 4 1/2" x 3 1/2"

6-14111 \$45.99



H. #148 DWARF SIGNAL

- Lights change from green to red when trains move through its block
- Automatically resets to green when train clears its block
- 153C Contactor included
- Dimensions: 1 3/4" x 1 3/4" x 2"

6-12883 \$26.99

I. #154 RAILROAD CROSSING FLASHER

- Die-cast metal construction
- Red lights flash when train passes by
- 153C Contactor included
- Also works with insulated track section (Sold separately)
- Dimensions: 9" height

6-12888 \$49.99

J. BANJO SIGNAL

- Die-cast metal construction
- Passing trains activate "banjo" mechanism
- 153C Contactor included
- Also works with insulated track section (Sold separately)
- Dimensions: 7 3/4" height

6-14090 \$59.99



BRIDGES AND TUNNELS

A. ARCH UNDER BRIDGE

- The Arch Under Bridge easily installs between Lionel elevated trestle piers.
- Compatible with O-27, O, and FasTrack track systems
- Integrates easily into your own layout design
- Dimensions: 19 ¼" x 3 5/8" x 4 7/8"

6-12770 \$26.99

B. VEHICLE GRADE CROSSINGS

- Traditional O gauge or O-27 track fits in molded grooves
- Set of two
- Dimensions: 3 ¼" x 7"

6-12839 \$6.99

C. TUNNEL PORTALS

- Portals with raised Lionel lettering
- Classic Postwar styling
- Set of two
- Dimensions: 7" x 8 ½"

6-12896 \$14.99

D. ROCK PIERS

- Classic Postwar styling
- Set of two
- Dimensions: 7" x 5" x 3"

6-12744 \$14.99

E. CURVED O GAUGE TUNNEL

- Durable, long lasting construction
- Simulated mountain terrain
- Realistic looking portal entrances
- For O-36 and O-48 FasTrack curved track
- Dimensions: Approx. 26" L x 16" W x 14" H

6-37810 \$39.99

F. STRAIGHT O GAUGE TUNNEL

- Durable long lasting construction
- Simulated mountainous façade design
- Portal entrances
- For straight track only
- Compatible with O-27, O, and FasTrack track systems
- Dimensions: 24" L x 10" W x 14" H

6-16868 \$39.99

G. BASCULE BRIDGE

- Powerful maintenance-free motor
- Red warning light on bridge top
- Sturdy metal construction
- FasTrack compatible
- Illuminated building
- Dimensions: 23" x 11" x 10"

6-37920 \$349.99

H. COVERED BRIDGE

A common sight on rural mainlines, covered bridges often took their share of wear and tear from the elements. Approximately two feet in length, the Lionel Covered Bridge is designed to accommodate O-27 gauge, O gauge, and FasTrack track sections.

- Compatible with O-27, O, and FasTrack track systems.
- Metal base
- Lighted interior
- Dimensions: 24 ½" x 7 ¾" x 8"

6-24117 \$54.99

I. SILVER TRUSS BRIDGE

- Compatible with O-27, O and FasTrack track systems
- Metal base
- Flashing red warning beacon on top of bridge
- Rock piers included
- Dimensions: 26 ⅞" x 7 ½" x 12 ½"

6-37900 \$69.99

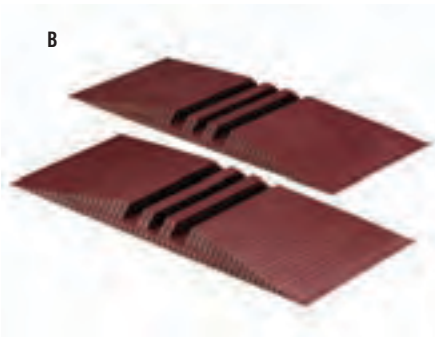

NEW

E



F



NEW

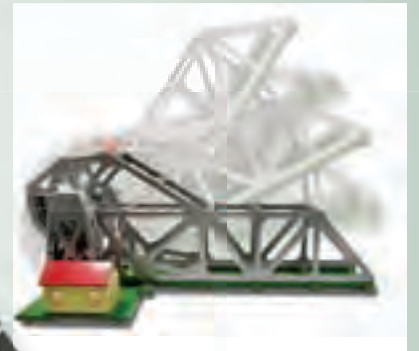

G



H

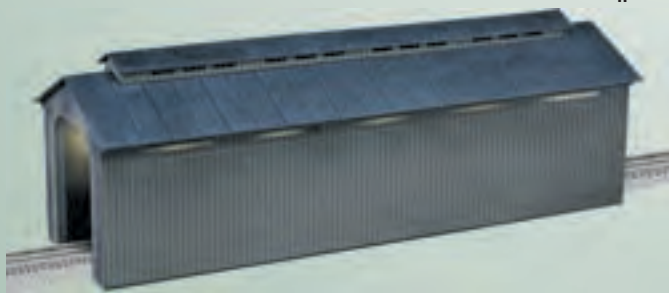

I



ACCESSORIES



A. LIGHTED COALING TOWER

In the steam era of railroading, coaling towers were stationed at multiple points along the rail lines and at terminals. It was an essential structure used to quickly refuel tenders with coal and keep the locomotives moving on time.

Lionel's Lighted Coaling Tower captures the classic cylindrical look of many towers from the late steam era. Standing on four tall legs, this tower is tall enough for nearly any engine or freight car to ride under. Featuring a wide variety of separately applied details and a lightly weathered look, it's incredibly realistic and a fitting addition to any traditional or high caliber layout. Look closely and you'll see various walkway decks, ladder chutes, and operating light fixtures. It even comes equipped with a movable coal chute that can be raised and lowered manually by pulling on the lift chains.

- Exterior illumination
- Realistic coal chute, pulleys and chains
- Coal chute can be raised and lowered manually

- Warning red light on top of tower
- Separately applied walkways and railings
- Separately applied ladder chutes and steps
- Dimensions: 5 1/2" x 5 1/2" x 19 1/2"
- Clearance: 5 1/4" from floor to entry ceiling

6-37912 \$179.99

B. HOPPER SHED

Add this realistic facility service structure to the work area of your layout. Place the Lionel Hopper Shed over your track and roll your engine in for repair. Featuring an exterior light at both ends, this structure is raised high to allow nearly any engine or rolling stock through the entry. With a slightly weathered, realistic paint, the Hopper Shed has the authentic look of the real-life structures.

- Two exterior lights
- Includes spacers to add height
- Dimensions: 8" x 4" x 6 1/2"
- Clearance: 5 3/4" from floor to entry ceiling with spacers
- 5 1/4" from floor to entry ceiling without spacers

6-37913 \$34.99

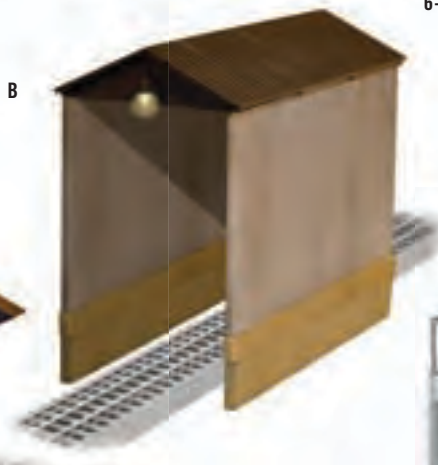

C. WORK HOUSE

This sturdy square building is the perfect place for workers to gather and discuss new projects on the horizon. Durable and realistically painted with a slightly-weathered look, it also features an operating exterior light that hangs above the side door and interior illumination.

- Illumination in interior and exterior
- Simulated window glass
- Dimensions: 3" x 2 1/2" x 2 1/2"

6-37914 \$27.99

D. SAND TOWER

This prototypical structure loads locomotives with sand to increase traction. Trains pass below the structure.

- Accommodates O and O-27 gauge track and the FastTrack track system
- Dimensions: 4 1/2" x 4" x 12"

6-14255 \$32.99

E. 50,000 GALLON WATER TOWER

An essential structure on any rail line in the steam era, railroad water tanks provided thirsty engines a place to stop and refill tenders with water. The new scale water tower by Lionel accurately depicts a 50,000 gallon version of this essential raiiside structure. Realistically detailed and scale in size, it is the perfect accessory to enhance any layout running scale-size steam locomotives. This new water tank features

a variety of separately applied details including a metal spout, ladders, and pulley chains. Additionally, the discharge water spout can be lowered manually as your train parks for a water stop.

- 1:48th scale
- Die-cast metal discharge spout
- Metal pulley chains
- Metal ladders, realistic tank hoop support rings, and other separately applied details
- Operating pulley system to lower and raise spout manually
- Simulated concrete piers
- Separately applied realistic tank hoop support rings
- Opening door on vertical frostbox
- Dimensions: Approx. 12" Height x 7" Diameter

6-16861 \$149.99

F. TANK CAR ACCIDENT

Accidents happen, even on the railroad! This all-new accessory brings that challenging scenario to light and adds another touch of realism to your layout. Passers by observe as the railroad workers clean up the mess from a dangerous tank car spill.

- Flickering welding light
- Die-cast sprung metal trucks on tank car
- Railroad worker figures
- Dimensions: 10" x 6" x 3 1/2"

6-16891 \$129.99



E



F



Welder with flickering welding light



Simulated liquid leaking from cover

AROUND THE NEIGHBORHOOD

A, B. SUBURBAN HOUSES

More realistic detail than ever before, Lionel's new suburban houses come to life on your layout. Some of the details include hedges, roof pipes, rain gutters, porch shades, flower boxes, and even birds resting their wings on the roof. Porch decks have the authentic look of real wood planks.

- Lighted interior
- Illuminated porch lamps
- A variety of realistic, separately applied detail
- Pre-assembled
- Dimensions:
 - Approx. 10" x 6 ½" x 4 ½" (red brick house)
 - Approx. 12 ½" x 8" x 6" (beige brick house)

A. 6-37916 Beige Brick Suburban House Deluxe \$79.99

B. 6-37917 Red Brick Suburban House Deluxe \$79.99





C



D

C. NEIL'S GUITAR SHOP

Music aficionados and rockers alike will be happy to hear that Neil's guitar shop is open for downtown business! Look for the giant illuminated guitar sign above the entrance of the building.

- Lighted guitar sign
- Illuminated interior
- Decorated interior
- Dimensions: 9 ¼" x 6" x 6"

6-16883 \$59.99

D. LEGACY HOTEL

Tired of driving? Take the next exit ahead and stop at The Legacy Hotel, a new 4-story establishment on Main Street of Lionelville. Loaded with new details, this special hotel includes a fire escape on the side, a lighted billboard and smokestack on the roof, and even an exhaust fan and central air units in the rear. Look through the windows to view realistic interior decoration and window drapery.

- Lighted interior
- Decorated interior
- Fire escape
- Realistic separately applied details on each side of the exterior
- Lighted billboard and smokestack on roof.
- Dimensions: Approx. 15" x 6" x 8 ½"

6-16847 \$69.99

LIONELVILLE

LIONELVILLE STRUCTURES

No railroad empire is complete without the buildings that make it look real! These perennial favorites are reintroduced as complete, decorated structures.

A. BARREL SHED

- Realistic decoration
- Uniquely detailed
- Interior illumination
- Dimensions: 4" x 3 3/4" x 3 3/8"

6-16881 \$29.99

B. COALING STATION

- Realistic decoration
- Interior illumination on both levels
- FasTrack compatible
- Dimensions: 13" x 9 1/8" x 9 1/8"

6-16874 \$79.99

C. FREIGHT PLATFORM

- Realistic decoration
- Opening door
- Interior illumination
- Dimensions: 8 1/2" x 5 1/2" x 4 1/2"

6-16880 \$29.99

LIONELVILLE PEOPLE PACKS

Populated your environments with Lionelville's broad range of characters and personalities. These detailed, hand-painted figures are made of tough pewter, and stand on sturdy bases.

- Hand-painted pewter
- Average height: 1 3/8"

D. 6-14241 Work Crew People Pack \$22.99

E. 6-24124 Carnival People Pack \$22.99

F. 6-24191 Park People Pack \$22.99

G. 6-14218 Downtown People Pack \$22.99

H. FLAGPOLE WITH LIGHTS

- Two flags
- Four illuminating lights on base
- Actual strings allows flags to be raised and lowered manually
- Dimensions: 3 3/4" x 3 3/4" x 11"

6-16896 \$24.99

I. OLD STYLE CLOCK TOWER

- Working clock with replaceable battery included
- Turn-of-the-century styling
- Dimensions: 4"

6-14147 \$42.99





D



E



F



H

I

NEW



G

ACCESSORIES

A-C. SUNOCO® OIL STORAGE TANKS

Create and expand your own industrial tank field with three new Sunoco oil tanks by Lionel! Highly detailed with operating light fixtures, walkway platforms, piping steps, and ladders, each oil structure adds realism to any industrial layout. These three oil tank plots can be also be connected in any combination to build a larger single industrial unit on your layout. A spherical and two distinct cylindrical storage tanks are available for 2010, each equipped with its own realistic base and surrounding walkway platforms.

Each Oil Tank Features

- Illuminated exterior
- Separately applied railings and pipes
- Realistic square base plot and surrounding walkways
- Detailed catwalks and railings (spherical and wide oil tank only)
- Detailed ladders

- Dimensions w/base: 10" L x 10" W x 10" H (Spherical Oil Tank)
- 10" L x 10" W x 7" H (Yellow Cylindrical Oil Tank)
- 10" L x 10" W x 8" H (Grey Cylindrical Oil Tank)

A. 6-37808 Sunoco® Spherical Oil Tank **\$99.99**

B. 6-16852 Sunoco® Yellow Cylindrical Oil Tank **\$89.99**

C. 6-16851 Sunoco® Grey Cylindrical Oil Tank **\$99.99**

SUNOCO® is a registered trademark of Sunoco, Inc. and its subsidiaries.

D. ILLUMINATED BARGE

Now your tugboat has something to push around! The all new Lionel railroad barge complete with tracks to put your rolling stock on as it's carried across the water.

- Illuminated exterior
- Removable simulated water base
- Display with removable deck house and loading platforms
- Realistic fixtures and decoration
- Dimensions: Approx. 21" X 8 ½"

6-37902 \$179.99

E. OPERATING LIGHTHOUSE

The Lionel Lighthouse stands tall as a beacon of light for all of your harbor traffic, keeping them safe from harm. This beautiful operating accessory guides the heavily loaded ships through treacherous waters, warning them to steer clear of the shoals and one another as they deliver the vital ore and coal to your waiting trains.

- Rotating beacon
- Illuminated buildings
- Realistic waterfront related sounds with volume control
- Foghorn sound is activated with the press of a button (included)
- Colorful figure
- Detailed lifeboat
- Dimensions: 7 ½" x 11" x 13 ¼"

6-37910 \$179.99

F. LEHIGH VALLEY TUGBOAT

The thought of railroads always conjures up majestic locomotives and rolling stock hauling freight and people across the many miles of countryside. However many railroads had to move their goods and people in port areas as well. For those railroads there was a need for transportation beyond their rail systems, and some maintained a small fleet of tugboats to move water bound shipments. These tugs would guide the ships and barges to an unloading point in local ports where the trains would then take over.

Lionel once again offers this option to you for use in your railroad empire. This beautifully detailed tugboat gives you the authority to control the flow of goods to your train world, as it stands ever watchful for the next shipment coming in to port.

- Operating smoke unit
- Tugboat horn sound
- Interior lighting in pilot house
- Metal handrails
- Removable simulated water base
- Dimensions: 19" x 5" x 11"

6-37901 \$269.99



A



Assemble these oil tanks together on your layout



B



C



REALISTIC LIGHTING



D



E



LIGHTS, SOUND, SMOKE

F

LIGHTS AND SOUND

ALL ITEMS NEW

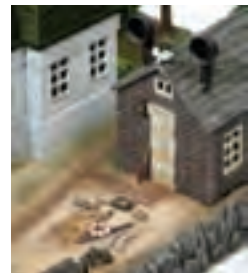

OPERATING ACCESSORIES

A. OPERATING SAWMILL

A classic Lionel accessory! See the logs enter into the sawmill by conveyor belt, hear the grind of the blade and watch in amazement as fresh wood planks come out of the other side. Safety strobe lights on both sides warn workers to be careful around the action. Together with your favorite Lionel log dump cars, the Lionel Sawmill can complete a classic logging railroad empire.

- Powerful maintenance-free motor
- Spinning blade
- Operating strobe lights
- Wooden logs and boards
- Works with Lionel log dump cars (not included)
- Dimensions: 16" x 6" x 6"

6-37919 \$129.99

B. OPERATING WIND TURBINE 3-PACK

One of the fastest growing alternative energy sources in the world, wind turbines efficiently convert the energy of the wind into electricity with minimal impact on the environment. Wind farms made up of a multitude of turbines are an increasingly common site throughout the nation and the world.

Start your own modern wind farm with the newly-tooled Operating Wind Turbine 3-pack. Over 15" in height, each operating turbine rotates at a realistic, constant speed. Accurately modeled details include spinning blades, "nacelle" housing, vertical tower, and base with tower entrance.

- Realistic rotation of turbine blades
- Constant rotating speed
- Base Height: 15 1/2"

6-16850 \$224.99

C. ROTARY AIRCRAFT BEACON

The Rotary Aircraft Beacon has a vibrating motor that rotates the beacon light.

- Metal construction
- Motor rotates beacon light
- Red and green lighting
- Dimensions: 5" x 5" x 12"

6-14097 \$80.99

D. CELL TOWER

- Red aircraft warning lights on top of tower
- Realistic looking microwave panels
- Dimensions: 2 1/2" x 2 1/2" x 16"

6-37903 \$59.99





3-PACK

**CONSTANT
ROTATING
SPEED**

B

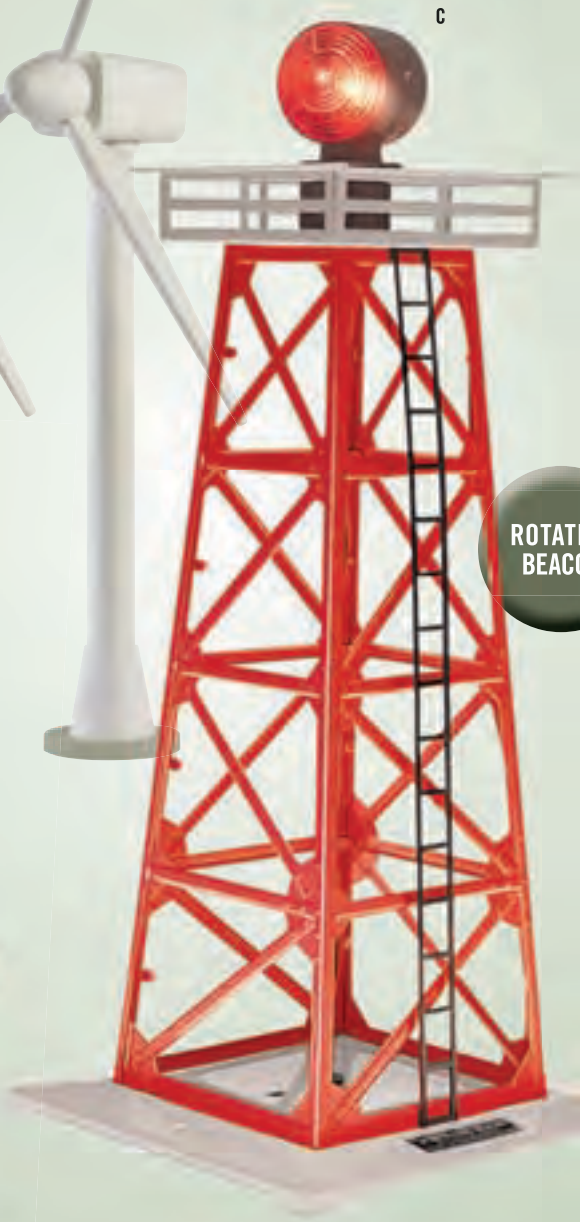

C

**ROTATING
BEACON**



D

NEW

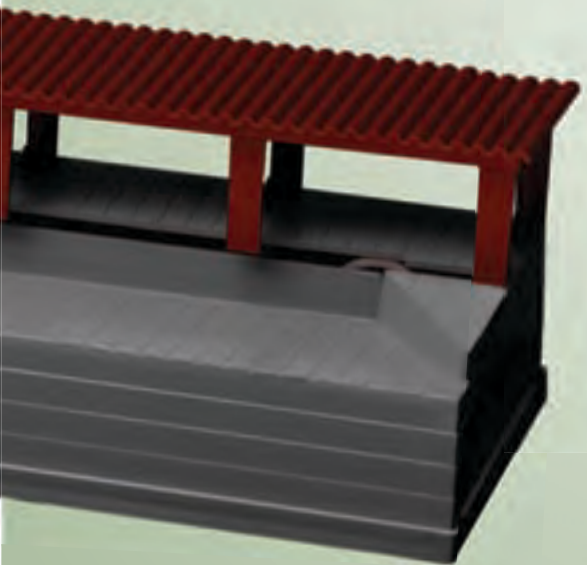

LIONELVILLE LIGHTS

A. LIONELVILLE STREET LAMPS

- Metal posts
- Removable bases for realistic mounting on your layout
- Set of four
- Dimensions: 3 ½" tall

6-24156 \$26.99



B



B. MAINLINE CLASSIC STREET LAMPS

- Brilliant illumination
- Classic Postwar styling
- Set of three green lamps
- Dimensions: 5 ½" tall

6-29247 \$39.99

TRESTLE SETS FOR FASTRACK® AND TRADITIONAL O SYSTEMS



FasTrack Trestle Brackets Snap Onto FasTrack Roadbed

F



H



C. FLOODLIGHT TOWER

- Illuminated from eight elevated bulbs
 - Tilted head
 - Dimensions: 12" height
- 6-14092 \$37.99**

D. #65 YARD LIGHTS 3-PACK

- Illumination from two elevated bulbs
 - Set of three
 - Dimensions: 6 1/4" height
- 6-12927 \$19.99**

E. #70 YARD LIGHTS 3-PACK

- Die-cast metal light housing
 - Metal center post
 - Set of three
 - Dimensions: 4 1/2" height
- 6-14071 \$34.99**

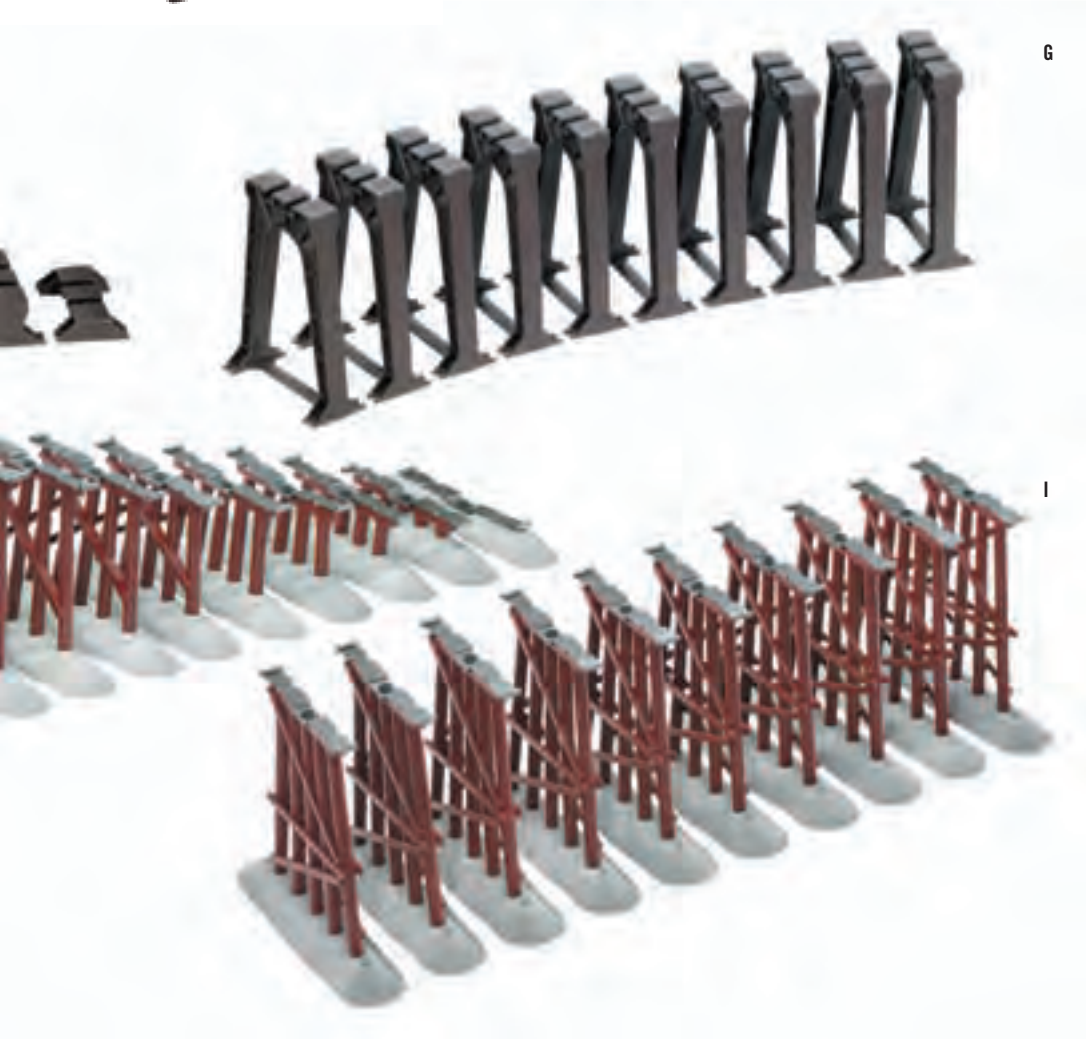

F. GRADUATED TRESTLE SET

- Incremental height grading
 - For use with traditional O and O-27 gauge track
 - Set of 22
 - Height: 4 3/4" (tallest trestle)
- 6-12754 \$26.99**

G. ELEVATED TRESTLE SET

- Create realistic raised-grade sections
 - For use with traditional O and O-27 gauge track
 - Set of 10
 - Height: 4 3/4"
- 6-12755 \$26.99**

H. FASTRACK GRADUATED TRESTLE SET

- Incremental height grading
 - For use with FasTrack track sections
 - Set of 22
 - Height: 5 1/2" (tallest trestle)
- 6-12037 \$74.99**

I. FASTRACK ELEVATED TRESTLE SET

- Create realistic raised-grade sections
 - For use with FasTrack track sections
 - Set of 10
 - Height: 5 1/2"
- 6-12038 \$39.99**

ACCESSORIES

A. LIONEL LOGO BAR STOOL

Ever since Lionel stools appeared briefly several years ago, collectors have been clamoring for their return. Now they're back! This hand sewn stool is made out of the finest materials in the USA with union labor. The stool features the Lionel "Since 1900" logo imprinted on the underside of durable vinyl, so it will not fade with usage. The body of the stool is made from high quality steel and chrome plated, so it is sure to be with you and your layouts for years to come.

- Image printed in reverse on the underside on clear 12 gauge vinyl
- 19 gauge steel and chrome plated frame
- Hand sewn seat
- Industrial ring and five 2x4's on the inside for support
- Cement adhesive staples used to lock supports in
- Made in USA with Union Labor
- 1 ¼" foam used for comfort

6-35529 \$129.99

Ships unassembled

B. BATHTUB GONDOLA COAL LOAD 3-PACK

When you're not using loose coal tipple in your bathtub gondolas, these new removable inserts will give your string of bathtub coal cars a realistic full-load appearance. Each pack includes three single-piece removable coal loads.

- Dimensions: 11 ½" x 2 ¼"

6-16873 \$19.99

C. THE LIONEL FASTRACK BOOK

This helpful guide explains how to use the Lionel FasTrack track system with more than 100 color photos and diagrams that show how to plan and create layouts for both large and small spaces. Dozens of track plans also show a variety of ways to integrate scenery and Lionel operating accessories to create a realistic layout. From small tabletop layouts, to large floor plans, there are many track ideas for you to explore, including double-track layouts for two trains, layouts to allow reversing trains, and any number of do-it-yourself designs. This book is a must-have for any Lionel train aficionado.

6-24200 \$34.99

D. THE LIONEL TRAIN BOOK

How to Build and Operate Your Own Model Railroad

Learn everything you need to know about setting up and maintaining a Lionel layout, and maximize the enjoyment of your Lionel trains, in the pages of the Lionel Train Book. Included in this reference guide are an overview of product development, updated instructions on the setup and use of the TrainMaster Command Control System, track plans for the floor and tabletop, advice on building scenery and structures,

wiring and track how-to, help in choosing steam or diesel locomotives and freight or passenger operations, maintenance and restoration tips, techniques, and instructions for operations that best emulate those of prototype railroads.

6-14190 \$29.95

E. LUBRICATION/MAINTENANCE SET

Includes gear lube, oil applicator, track cleaning fluid, track-cleaning eraser and cleaning instructions

6-62927 \$22.49

F. SMOKE FLUID

Designed for use with all Lionel locomotives, rolling stock, and accessories that feature smoke units.

6-62909 2 fl. oz. \$8.59

G. ICE BLOCK PACK

- For use with the Icing Station and Ice Car
- Set of ten

6-14240 \$6.29

H. DIE-CAST METAL SPRUNG TRUCKS

- Metal coupler armature
- Quick and easy to install
- Adds weight and improves tracking
- Box of two

6-14078 \$19.99

I. DIE-CAST METAL SPRUNG TRUCKS WITH ROTATING BEARING CAPS

- Rotating bearing caps
- Metal coupler armature
- Quick and easy to install
- Adds weight and improves tracking
- Box of two

6-14251 \$20.49

A



B



C



D

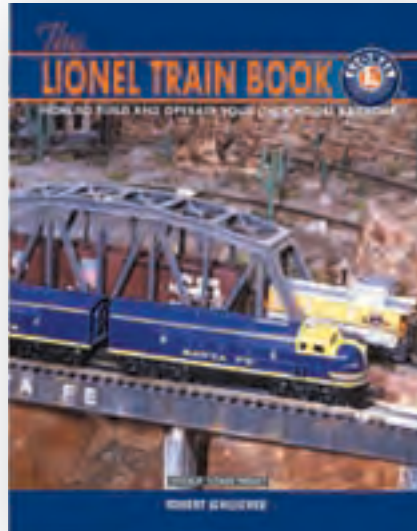

E



F



G



H



I



LEGACY™ ONE REMOTE. ONE BASE. ONE SYSTEM.

Here's all you need to get started...

A. #990 LEGACY COMMAND SET

The #990 LEGACY Command Set features a #991 LEGACY CAB-2 Remote Controller and a #992 LEGACY Command Base/Charger, the two components you need to get started. Only one LEGACY Command Base/Charger is required per layout.

Like traditional TMCC, the LEGACY Command Base/Charger receives information from the Remote Controller and sends it out to the track via a simple one-wire connection. But that's not all. The LEGACY Command Base/Charger remembers information about your layout, enabling the CAB-2 Remote Controller to display road names and numbers on the LCD screen.

SET INCLUDES:

- #991 LEGACY CAB-2 Remote Controller
- #992 LEGACY Command Base/Charger

CAB-2 Remote Controller Features:

- Back-lit LCD screen—the largest on the market
- Back-lit LCD keypad displays numbers or icons for ease of use
- Built-in rechargeable batteries
- Feedback mode—the remote vibrates to reinforce the effort and momentum of your locomotive
- Accepts memory modules from each LEGACY Control System locomotive

Command Base/Charger Features:

- Only one LEGACY Command Base/Charger required per layout
- Simple one-wire connection to your layout
- Built-in dock for recharging CAB-2 Remote Controller
- Stores operating information and settings for your layout

6-14295 #990 LEGACY Command Set \$349.99

Add additional remotes for your layout...

B. #993 LEGACY EXPANSION SET

Need additional remotes? The #993 LEGACY Expansion Set includes a #991 LEGACY CAB-2 Remote Controller and a #994 LEGACY Charger Base

SET INCLUDES:

- #991 LEGACY CAB-2 Remote Controller
- #994 LEGACY Charger Base

Charger Base Features:

- Built-in dock for recharging additional CAB-2 Remote Controllers
- Add as many as you like to charge remotes simultaneously

6-14294 #993 LEGACY Expansion Set \$289.99

C. #996 POWERMASTER BRIDGE

Layouts using the Lionel PowerMaster 6-24130 can transition to full CAB-2 operation with the new #996 PowerMaster Bridge. The PowerMaster Bridge allows you to replace your TMCC CAB-1 with a LEGACY CAB-2 to vary voltage, change locomotive direction, adjust speed, and control sounds remotely.

- Dimensions: 10 1/2" x 3" x 2 3/8"

6-24279 #996 PowerMaster Bridge \$54.99

A



B



C





A. ICONIC AND GRAPHIC CONTROL MONITORING

Icons and graphs represent most of control functions. Icons are large and easy to view. Graphs are bold and easy to understand.

- **Speed Graphing** Operators can access a large graph in the remote display window that illustrates target speed, command speed, rate of acceleration, and train brake settings.
- **Iconic Route Set-Up** In route set-up, animated icons form a line across the screen that illustrates the route as it is set up. Switches become animated when the route is thrown.
- **Iconic Train Lash-Up** Using icons, engines are displayed in the order that they are assigned to a lash-up. Engine icons can be manipulated to automatically make changes in direction or in engine order.

B. TRAIN BRAKE

Provides more realistic and precise brake control than any other system available.

C. MULTI-CONTROLLER BOOST BRAKE AND DIRECTION

Get braking and boosting from any given speed!

- Push up to boost...back off a little to hold the new “boosted” speed...release to return to throttle set speed.
- Pull down to brake...back off a little to hold the new “brake” speed...release to return to throttle set speed.
- In the center or “released” position, press down for a direction change.
- If you wish, set the direction function to stall your moving train without changing direction. In this mode, pressing the direction control while your train is stopped will provide a direction change.



D. RECORD FEATURE

Record any action that you want to see repeated.

E. VELOCITY THROTTLE

The velocity throttle changes speed steps faster as it is rotated faster. For example, turning the throttle slowly results in the highest resolution—with 200 speed steps. The train can go from a complete stop to full throttle in either one rotation of the knob or in five rotations, depending on how fast the throttle is turned.

F. BACK-LIT LCD DISPLAY

Simple icons represent a wide variety of control functions, route set-ups, and train lash-ups. Easy to read graphs illustrate numerous speed, acceleration, and brake settings.

G. ADDRESSING FUNCTIONS

Select any object on your layout by scrolling through names alphabetically or by entering the multiple digit road number painted on the side of your engine. For accessories, use the LIONEL two- and three-digit numbers if you like. (For older engines, a simple method of adding the information manually can be used and traditional TMCC addressing is still available.)

H. VARIABLE HORN CONTROL

As the whistle/horn control is pulled, the horn is played with increasing intensity. Develop your own whistle/horn “signature” and control the warning sound in real time!

I. LCD TOUCHSCREEN KEYPAD

Control complicated model railroad layouts with ease. When addressing, the numbers are visible; during operation, control icons are automatically displayed.

J. FEEDBACK/VIBRATION

The remote rumbles as your locomotive accelerates and brakes! This unique control feature reinforces the sense of weight and momentum of the locomotive.

K. GRAPHIC ADJUSTABLE MOMENTUM

Set the momentum of the train or engine to low, medium, or high. The value of each momentum setting is adjustable and unique to that engine or train.

LEGACY™ CONTROL SYSTEM BUYER'S GUIDE

OPERATING CONVENTIONAL LOCOMOTIVES ONLY

Operating conventional locomotives from your CAB-2 Remote Controller is very simple. Forget about rewiring your trains or spending the day making track connections—installing the LEGACY Control System is much easier than that!

WHAT YOU NEED

- Choose one: PowerHouse Power Supply 6-22983 OR another 18-volt transformer with a Power Adapter Cable 6-12893
- Choose one: PowerMaster 6-24130, PowerMaster Bridge 6-24279, TMCC Track Power Controller 300 6-14189 OR TMCC Track Power Controller 400 6-14179
- #990 LEGACY Command Set 6-14295

OPERATING BOTH CONVENTIONAL AND COMMAND-EQUIPPED LOCOMOTIVES

Want to operate both conventional and Command-equipped locomotives? No problem! While they can't share the same block of track at the same time, both types of locomotives can operate on your layout.

WHAT YOU NEED

- Choose one: PowerHouse Power Supply 6-22983 OR another 18-volt transformer with a Power Adapter Cable 6-12893
- Choose one: PowerMaster 6-24130 PowerMaster Bridge 6-24279, TMCC Track Power Controller 300 6-14189 OR TMCC Track Power Controller 400 6-14179
- #990 LEGACY Command Set 6-14295

CONTROLLING ENTIRE LAYOUT FROM THE CAB-1 REMOTE: SWITCHES, ROUTES & ACCESSORIES

- SC-2 Switch and Accessory Controller 6-22980—Controls up to twelve accessories or six switches, or four switches/two accessories.
- Accessory Switch Controller 6-14182 Controls up to eight accessories or four switches with ten routes.
- Operating Track Controller 6-14185 Eliminates the individual Remote Control Track controllers and control buttons.
- Block Power Controller 6-14184—Acts like a rotary switch to allow you to route power from any PowerMaster or Track Power Controller to your blocks of track and sidings.

OPERATING ONLY TRAINMASTER COMMAND CONTROL-EQUIPPED LOCOMOTIVES

Operating only Command-equipped locomotives is very simple. With a Command Base and a standard transformer or a PowerHouse Power Supply, you are ready to take control!

WHAT YOU NEED

- Choose one: PowerHouse Power Supply 6-22983 and a TMCC Direct Lockon 6-34120 OR an 18-volt power supply (we recommend the famous Lionel ZW transformer controller 6-32930)
- #990 LEGACY Command Set 6-14295

LEGACY CONTROL SYSTEM AND TMCC COMPONENTS

Use this guide to help you determine what components you'll need to get started with the LEGACY and TMCC systems.



BETTER



GOOD



Throw switches and activate accessories at the press of a button

TMCC SC-2 SWITCH CONTROLLER

For more flexibility in controlling switches and accessories, the SC-2 is the perfect choice.

- Programmable to control four switches AND four accessories together OR six switches OR 12 accessories
- Controls up to nine programmed routes
- Toggles accessories ON and OFF
- Controls switches from several manufacturers
- Power supply included
- Communicates with the Command Base without the need for wires

6-22980 \$119.99

TMCC ACCESSORY SWITCH CONTROLLER (ASC)

Operate switches or activate accessories from the CAB Remote Controller.

- Programmable to control up to eight accessories OR four switches
- Controls up to 10 programmed routes in switch mode
- Toggles accessories ON and OFF
- Controls switches from several manufacturers
- Connects to the Command Base

6-14182 \$103.99



Direct track power from several sources to control your conventional locomotives!

TMCC BLOCK POWER CONTROLLER (BPC)

Manage the power in your blocks from the CAB Remote Controller.

- Routes power from any TMCC PowerMaster or TPC to any block of track
- Eliminates the need for multiple PowerMasters or TPCs on each block of track
- Enhances conventional operation by connecting multiple blocks to one TPC,
- Allowing for travel across blocks without having to match the voltage between them
- Is programmable to channel power from four TPCs to two blocks OR from two TPCs to four blocks

6-14184 \$103.99



Operate motorized accessories with prototypical speed and direction!

TMCC ACCESSORY MOTOR CONTROLLER (AMC)

The AMC gives you control over your accessories like never before. When used in conjunction with lights, the AMC allows you to control bulb brightness from the CAB Remote Controller. When used in conjunction with your accessories' motors, the AMC gives you control over operation. You can spin the cab on a gantry crane with the red knob, or raise and lower the boom with the CAB Remote Controller buttons.

- Precise motor and/or light control
- Operation of accessory speed, direction, or function from the CAB Remote Controller
- Two modes allow you to take fine control of accessory motor functions (e.g., gantry crane cab rotates as you rotate CAB Remote Controller knob in whichever direction you are turning OR accessory operates in its normal way as long as you give it the command to operate)
- Programmable accessory motor speed or light intensity
- Operates up to four motors or up to four lights

6-14183 \$114.99

Run any 0 gauge locomotive ever made!

GOOD



BETTER



BEST



TMCC POWERMASTER

Allows you to run non-TMCC locomotives remotely.

- Control non-TMCC locomotives from the CAB Remote Controller
- Vary track voltage
- Change locomotive direction, vary speed, operate whistle and bell
- Regulates up to 135 watts of power or 180 watts of power – customer selectable

6-24130 \$78.99

Power supply not included

TMCC TRACK POWER CONTROLLER (TPC) 300

The TPC 300 combines the features of the PowerMaster plus:

- Operates M.T.H.® Proto-Sound® 2.0 locomotives in conventional mode
- Improved operation at low speeds
- Regulates up to 300 watts of power

6-14189 \$169.99

Power supply not included

TMCC TRACK POWER CONTROLLER (TPC) 400

The TPC 400 combines the features of the TPC 300 plus:

- Regulates up to 400 watts of power

6-14179 \$229.99

Power supply not included



Activate your Remote-Control Track sections!

TMCC OPERATING TRACK CONTROLLER (OTC)

Use the OTC to remove all of the hard-wired Operating Track activation buttons on your layout.

- Operates Remote-Control and Uncoupling Track sections from the CAB Remote Controller
- Uncouples, unloads, or activates operating rolling stock from the touch of a button on the CAB Remote Controller
- Is programmable to operate two Remote-Control Track sections OR four Uncoupling Track sections

6-14185 \$90.99

Record your favorite scenarios and play them over and over again!

TMCC ACTION RECORDER CONTROLLER (ARC)

Record layout scenarios using your trains and accessories, and play them back with the touch of a button on the CAB Remote Controller

- Make and save up to eight recordings

6-14181 \$114.99

Fine-tune the accessory voltage!

TMCC ACCESSORY VOLTAGE CONTROLLER (AVC)

Extend the life of your favorite accessories by fine-tuning the voltage they receive. From the CAB Remote Controller, you can set the voltage that your hooked-in accessories receive from their power source.

- Remote-control voltage setting
- Helps prolong the life of lamps and motors

6-14186 \$160.99



A. POWER ADAPTER CABLE

The Power Adapter Cable connects your transformer to a PowerMaster 6-24130 for operating LEGACY, TMCC and non-TMCC equipped locomotives.

6-12893 \$16.99



B. 3-WIRE COMMAND BASE CABLE

The 3-Wire Command Base Cable connects the TMCC ARC to the Command Base 6-12911.

6-14192 \$13.39

Use Command Base Cable 6-14191 for layouts that do not include a TMCC ARC.



C. COMMAND BASE CABLE

The Command Base Cable connects a TMCC controller to the Command Base 6-12911).

6-14191 6 ft. \$12.19

TMCC TPC CABLE SET

The TMCC TPC Cable Set connects parallel PowerHouse transformers to the TPC 300/400. The set also includes adapter plugs to wire your transformer to the TPC 300/400.

6-14194 \$15.99

CONTROLLER TO CONTROLLER CABLE

The Controller to Controller Cable connects the TMCC controllers together.

6-14193 1 ft. \$4.89

6-14196 6 ft. \$7.99

ZW-L TRANSFORMER

Lionel introduces a new and more advanced version of the classic ZW Transformer.

A. ZW-L TRANSFORMER

No single product has come to symbolize the legend of Lionel more than the Lionel ZW. That's why we're especially proud to announce a new and more advanced version of the Lionel classic – The Lionel ZW-L Transformer. True to the signature design elements of the original, the ZW-L is molded in phenolic resin and features the same distinctive four-handle operation as its predecessor. The ZW-L can run up to four trains or accessories at the same time on different layouts. The two engineer-type handles provide independent control of two variable voltage circuits, each with built-in whistle, direction, and bell controls. Two additional accessory circuits can be set by means of the dial-type controls to any desired voltage.

The ZW-L Transformer is designed to give you smoother operation and more realistic control of your engines and accessories. Operation of the four handles now allows for fine control of up to 200 speed steps. It also provides a wider range of control at the minimum and maximum extensions of handle dial motion, and comes equipped with a smoother, more durable handle gearing system. Voltage and current from each of the four channels of the ZW-L Transformer are cleanly displayed in four easy-to-read, analog ammeter/voltmeter dials that are housed in the "dashboard" face. A full 720-watts of power are built inside the unit, so there's no need for separate power bricks. To keep your Controller operating safely, the ZW-L also comes equipped with an automatic temperature controlled cooling fan, a circuit breaker for each channel output, and an on/off switch on the front. Additionally, LIONEL letters light up in blue on the front face of the unit when the ZW-L is turned on.

Whether you run vintage or state of the art locomotives and accessories, the new Lionel ZW-L Transformer provides more realistic conventional control of your layout operations than ever before!

6-37921

B. TMCC DIRECT LOCKON

Connect your PowerHouse Power Supply directly to the track with the TMCC Direct Lockon. Featuring a selectable current setting for the 135-Watt or 180-Watt PowerHouses), the Direct Lockon eliminates the need for a PowerMaster if you run only TMCC- or LEGACY-equipped locomotives. For added safety, the Direct Lockon provides over-current protection and an automatic reset. It is compatible with both Lionel FasTrack and O/027 track systems. Includes power wire with FasTrack connectors and one standard Lionel Lockon.

6-34120 \$51.79

C. 180-WATT POWERHOUSE POWER SUPPLY

Power your railroad empire with an advanced 180-Watt PowerHouse Power Supply. UL® - listed for safe operation, this mighty power supply is perfect for your TMCC Track Power Controller or Direct Lockon.

6-22983 \$99.99

D. 1.8 AMP ACCESSORY TRANSFORMER

Power your Lionel accessories with the 1.8 Amp Accessory Transformer. This affordable power supply features variable AC voltage so you can supply the right amount of power to your accessories.

6-32923 \$45.99

E. CW-80 80-WATT TRANSFORMER

Enjoy operating your favorite locomotives, train sets, and accessories with the 80-Watt CW-80 Transformer. From the handsomely designed controller, reminiscent of the famous Lionel ZW, you control speed and power by raising and lowering the engineer handle. Operate your favorite features with the bell, whistle/horn, and direction buttons. On the rear of the unit, you will find a 0-18 volt variable AC output, as well as a programmable AC output for accessory operation. Simply set the accessory voltage to your desired output, and your accessory operates at that output until you turn the unit off—even when you stop the train! Perfect for train sets and small- to medium-sized layouts, the CW-80 provides the power you need to enjoy all your Lionel favorites.

6-14198 \$143.99

B



C



D



E





LIONEL'S EXCLUSIVE
PREVIEW



A

FASTRACK

Consider the advantages

Offering innovation, variety, ease-of-use, and a fantastic prototypical look, the FasTrack track system brings your Lionel layout to life like never before. Its flawless performance and endless flexibility make it appealing to first-timers and seasoned pros alike.

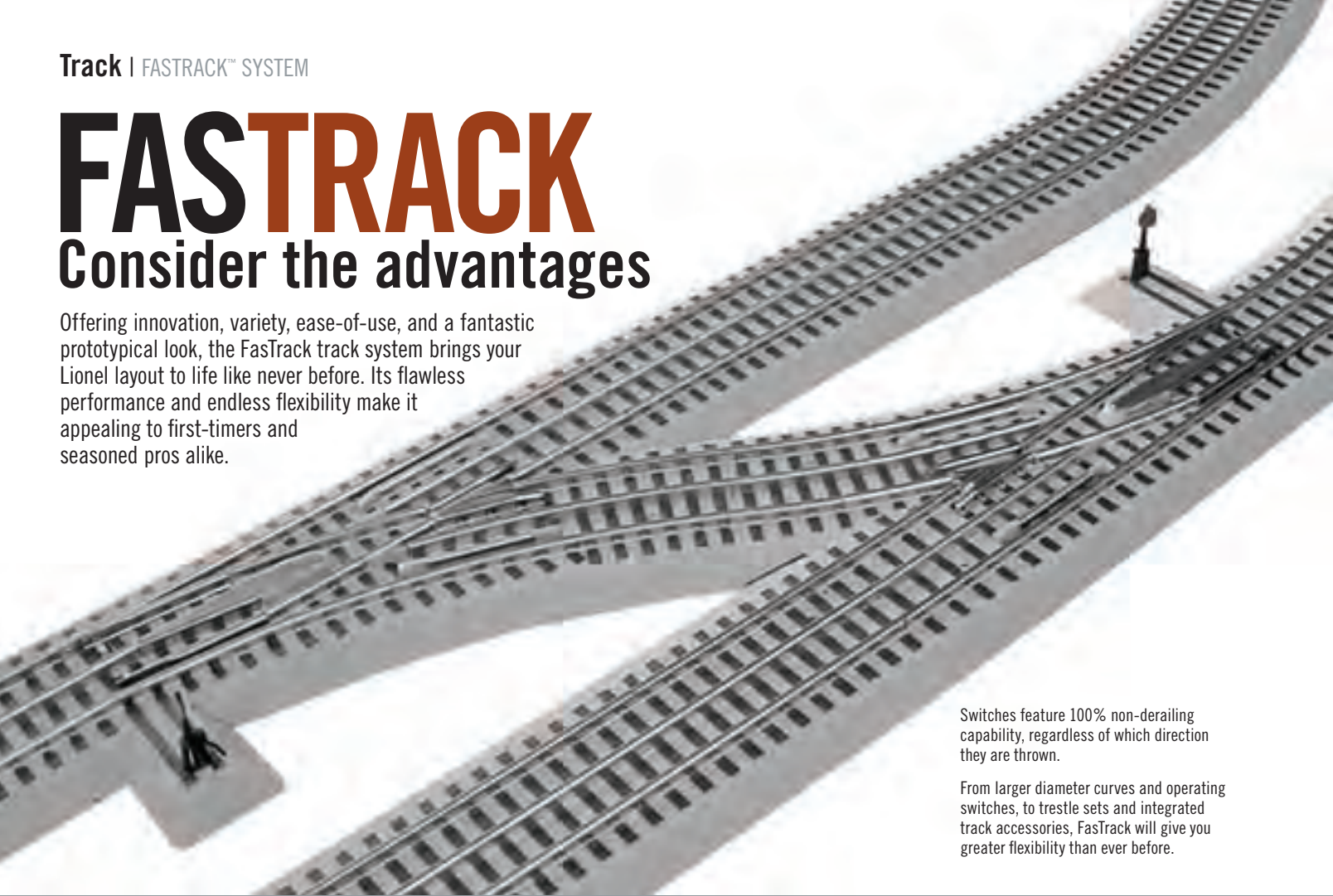

Switches feature 100% non-derailing capability, regardless of which direction they are thrown.

From larger diameter curves and operating switches, to trestle sets and integrated track accessories, FasTrack will give you greater flexibility than ever before.



Curves are O-36 to give locomotives a more realistic appearance around corners. The larger diameter also allows for the operation of larger locomotives than is possible on O-27 or O-31 curves.



Two terminals under each piece of straight track and one terminal under each piece of curved track for transformer and/or accessory power connections – no Lockons required!

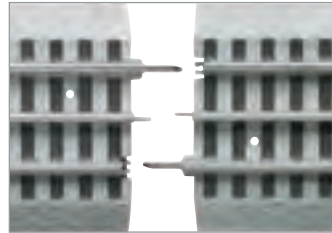

Easy, snap-together locking mechanism for sure connections.

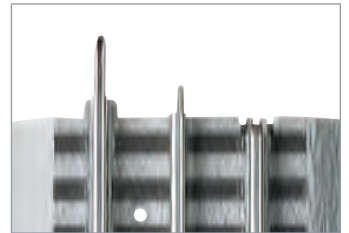

Patented center half-pin allows for track orientation in either direction without the need for moving pins from one end to the next.

Accessory Hook-ups and Operation — with FASTRACK, it's Simple!

HOOK-UPS

Under the roadbed of all straight and curved sections are electrical terminals. You can hook up to these terminals in different ways.

- If you already have wire for your accessories, or you have pre-wired accessories, purchase 18-gauge quick connectors from your local electronics supply store. Strip wires back approximately 1/4", insert wire into the quick connector, and crimp it into place

Operation

- Use a 1531R controller. The 1531R works the same way it does for O-27 and O gauge operation, with the power Lockon connector removed. Follow the instructions to hook up the accessory, and power your accessory as outlined left.
- Or use the FasTrack Accessory Activator Pack, which includes one insulated 10" straight track section and two 5" isolated track sections. Hook up your accessory to the insulated section as outlined left. The isolated sections have a break in the center of one track rail. As a train passes

over this break, its wheels complete the circuit and power is supplied to the entire length of track in between the breaks of the isolated sections – including the insulated section placed between them. To increase the length of time over which the accessory operates, simply add more insulated track sections between the two isolated sections. This technique is the equivalent of using Lionel insulated track sections in O/O-27, and is used only with accessories that perform one function in an on/off manner (e.g., Crossing Gate, Auto Gateman, etc.)



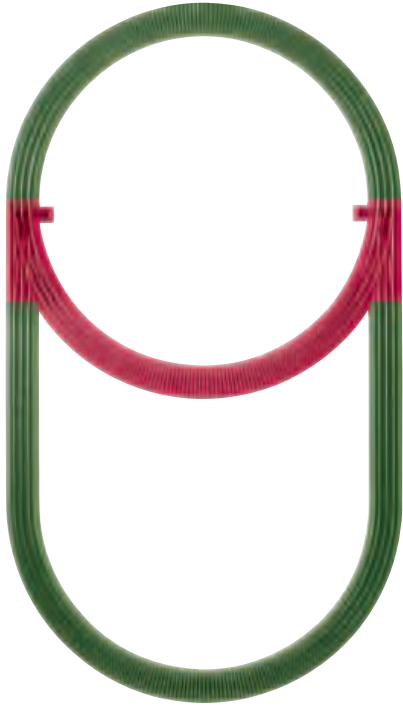

INNER PASSING LOOP ADD-ON TRACK PACK

Layout dimensions: 39 1/2" x 70 1/2" Track Pack includes:

036 Curve 6-12015	QTY. 2
RH Manual Switch w/Quarter Curve 6-12018	QTY. 1
LH Manual Switch w/Quarter Curve 6-12017	QTY. 1

6-12028 \$99.99

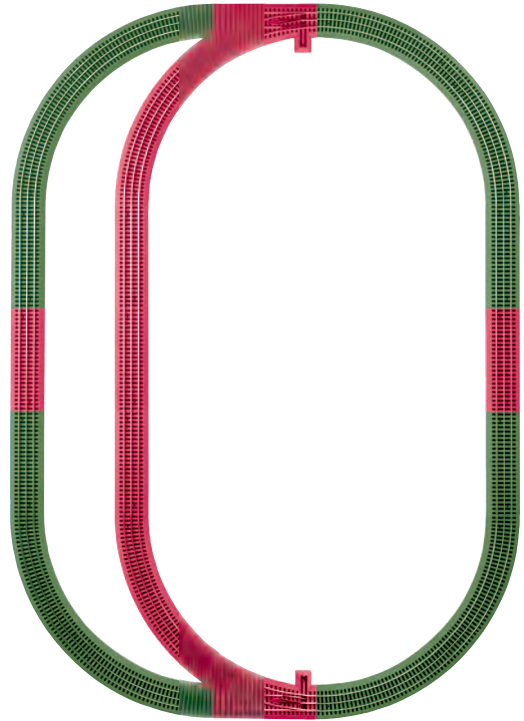

OUTER PASSING LOOP ADD-ON TRACK PACK

Layout dimensions: 49 1/2" x 70 1/2" Track Pack includes:

10" Straight 6-12014	QTY. 5
036 Curve 6-12015	QTY. 2
RH Manual Switch w/Quarter Curve 6-12018	QTY. 1
LH Manual Switch w/Quarter Curve 6-12017	QTY. 1

6-12031 \$114.99

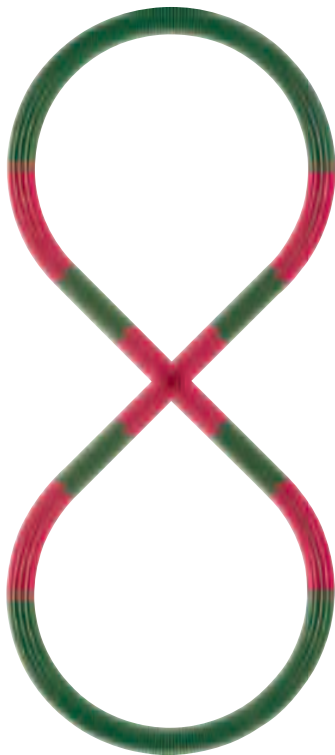
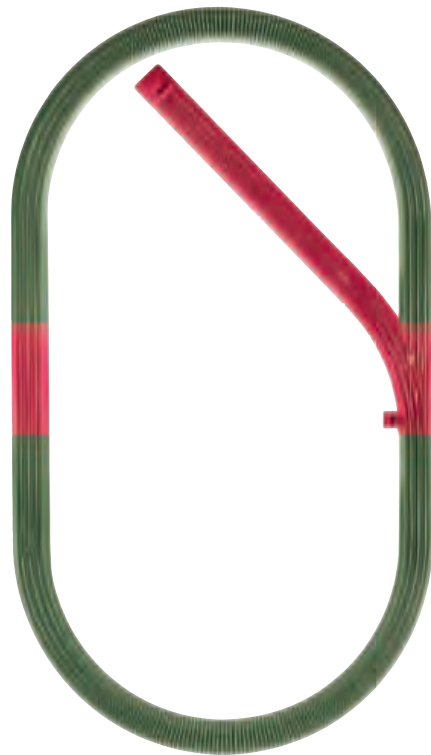

FIGURE 8 ADD-ON TRACK PACK

Layout dimensions: 39 1/2" x 90 1/2" Track Pack includes:

036 Curve 6-12015	QTY. 4
5" Straight 6-12024	QTY. 4
90-Degree Crossover 6-12019	QTY. 1

6-12030 \$66.99



SIDING TRACK ADD-ON TRACK PACK

Layout dimensions: 39 1/2" x 70 1/2" Track Pack includes:

10" Straight 6-12014	QTY. 3
Uncoupling Track 6-12020	QTY. 1
Earthen Bumper 6-12059	QTY. 1
Quarter Curve 6-12017	QTY. 1

6-12044 \$105.99

Straight Track Sections

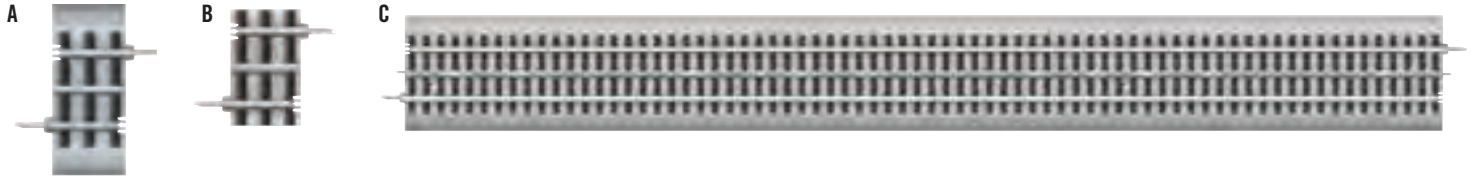

A. 1 3/8" TRACK SECTION 6-12073 \$4.59	B. 1 3/8" TRACK SECTION WITHOUT ROADBED 6-12074 \$4.59	10" STRAIGHT TRACK 6-12014 \$4.79	4 1/2" STRAIGHT TRACK 6-12025 \$4.59	C. 30" STRAIGHT TRACK 6-12042 \$14.59
		5" HALF STRAIGHT TRACK 6-12024 \$4.59	1 3/4" STRAIGHT TRACK 6-12026 \$4.59	10" STRAIGHT TRACK 4-PACK 6-12032 \$20.99

Curved Track Sections

036 CURVED TRACK (8 pieces per circle) 45-Degree section 6-12015 \$4.79	048 CURVED TRACK (12 pieces per circle) 30-Degree section 6-12043 \$4.59	060 CURVED TRACK (16 pieces per circle) 22 1/2-Degree section 6-12056 \$6.89
036 HALF CURVED TRACK (16 pieces per circle) 22 1/2-Degree section 6-12022 \$4.59	048 HALF CURVED TRACK (24 pieces per circle) 15-Degree section 6-16834 \$4.59	072 CURVED TRACK (16 pieces per circle) 22 1/2-Degree section 6-12041 \$6.89
036 QUARTER CURVED TRACK (32 pieces per circle) 11 1/4-Degree section 6-12023 \$4.59	048 QUARTER CURVED TRACK (NEW) (48 pieces per circle) 7 1/2-Degree section 6-16835 \$4.39	072 HALF CURVED TRACK (32 pieces per circle) 11 1/4-Degree section 6-12055 \$5.79

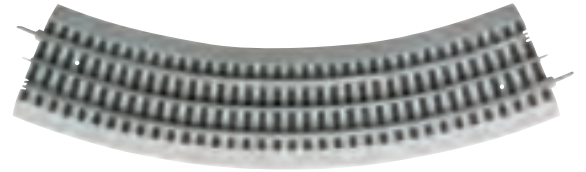

084 CURVED TRACK (32 pieces per circle) 11 1/4-Degree section 6-12061 \$6.89	036 CURVED TRACK 4-PACK (Creates a half-circle) 6-12033 \$20.99
--	--

Specialty Track Sections

TRANSITION PIECE

- Connects with traditional O gauge track
- Length: 5"

6-12040 \$9.19



BLOCK SECTION

- Used to make an isolated track block
- Wires jump the breaks in the track on the underside of the roadbed

6-12060 \$9.19



UNCOUPLING TRACK

- Central magnet is activated by remote control (included)
- Includes a Half Straight Track section
- Length of each section: 5"

6-12020 \$41.99

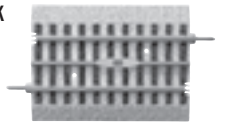

TERMINAL SECTION

- Includes wires that connect the track to your transformer
- Length: 10"

6-12016 \$7.99

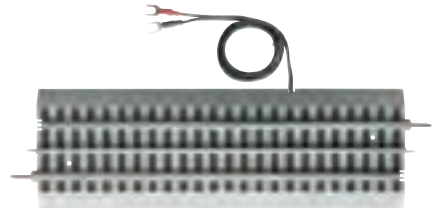

OPERATING TRACK

- Central magnet and control rails are activated by remote control (included)
- Length: 10"

6-12054 \$42.99



Accessory Activator Extenders

ACCESSORY ACTIVATOR EXTENDER

- Length: 10"

6-12027 \$4.59



ACCESSORY ACTIVATOR PACK

- Includes one 10" Insulated section and two 5" Isolated sections

6-12029 \$13.79



Track Crossovers

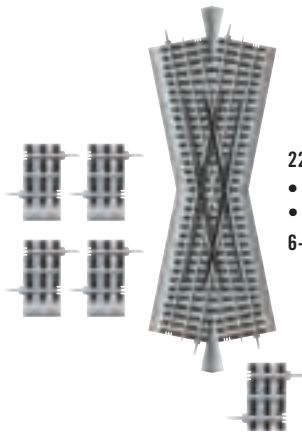

22 1/2-DEGREE CROSSOVER

- Removable 1 3/8" extensions
- Length: 17" X 17"

6-12050 \$45.99

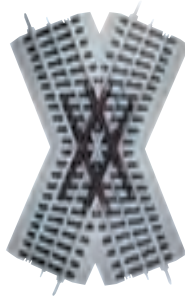

45-DEGREE CROSSOVER

- Length: 10" x 10"

6-12051 \$23.99

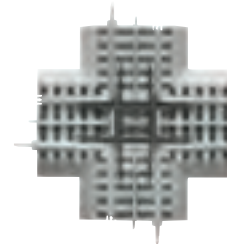

90-DEGREE CROSSOVER

- Length: 6" x 6"

6-12019 \$22.99

Track Accessories



GRADE CROSSING

- Length: 10" track section, 6 1/4" wide road section
- two per package

6-12036 \$13.79



GRADE CROSSING WITH GATES AND FLASHERS

- Features operating crossing gates, flashers, and bell sounds
 - Length: Approx. 10", 6 1/4" road section
- 6-12062 \$159.99

GRADE CROSSING WITH FLASHERS

- Features two flashing signals and bell sounds
 - Length: 10" track section, 6 1/4" road section
- 6-12052 \$91.99

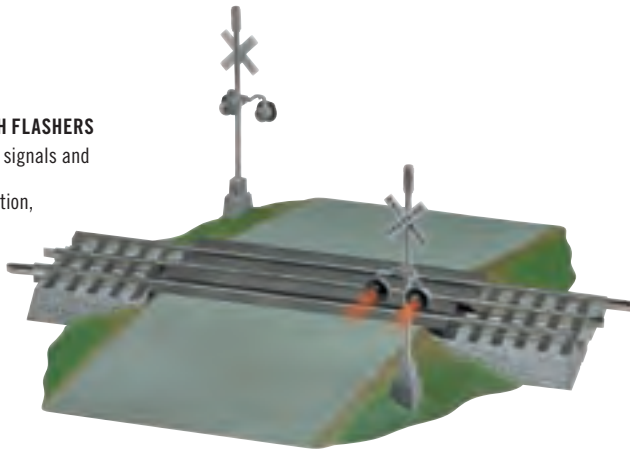

EARTHEN BUMPER

- Length: 3 3/8"
 - Real wood bumper
 - two per package
- 6-12059 \$9.19



LIGHTED BUMPER

- Two per package
 - Length: 5"
- 6-12035 \$29.99



A. RAILER

- Length: 10"
- Also compatible with traditional O gauge and O-27 gauge track

6-12039 \$9.19

B. ACCESSORY POWER WIRE

6-12053 \$5.79



Track Extras

FASTRACK

FasTrack switches raise the bar in performance and features for maximum enjoyment of your trains. Build the layout of your dreams today!

Bulletproof switches are the foundation of any track system. They allow you to grow and expand your layout. Lionel FasTrack switches are second to none when it comes to durability and innovative, industry-leading features:

- Flawless, non-derailing function allows trains to keep running regardless of switch position
- Plug-and-play operation using track voltage or auxiliary power
- Auxiliary power and TMCC (ASC and SC-2) terminals are conveniently located under the roadbed base, making all connections invisible from above
- Realistic switch lamp
- Lantern base is interchangeable, can move to the right or left side

Additional Features for Remote Switches Include:

- Remote switch controllers conveniently lock together for easy access
- Interchangeable number inserts allow you to instantly find the switch you want to control red and green LEDs indicate switch position on remote switches, no need to change light bulbs or worry about heat build up

036 FASTRACK SWITCHES FEATURE

- 33 ¾ -Degree turnout
- Includes 1/4 curve to complete 0-36 45-Degree curve
- Length: 10" straight,

- A. 6-12046 036 Remote Switch-Right Hand \$91.99
- 6-12017 036 Manual Switch-Left Hand \$44.99
- 6-12018 036 Manual Switch-Right Hand \$44.99
- 6-12045 036 Remote Switch-Left Hand \$91.99
- 6-16824 036 Command Control Switch-

Left Hand \$109.99

- 6-16825 036 Command Control Switch-Right Hand \$109.99

048 FASTRACK SWITCHES FEATURE

- 30-Degree turnout
- Length: 15" straight

- 6-12065 048 Remote Switch Left Hand \$103.99
- 6-12066 048 Remote Switch Right Hand \$103.99
- 6-16830 048 Command Control Switch Left Hand \$119.99
- 6-16831 048 Command Control Switch Right Hand \$119.99

060 FASTRACK SWITCHES FEATURE

- 22 ½-Degree turnout
- Removable 1 3/8" extensions
- Length: 14 ½" straight

- B. 6-12058 060 Remote Switch-Right Hand \$103.99
- 6-12057 060 Remote Switch-Left Hand \$103.99
- 6-16828 060 Command Control Switch-Left Hand \$119.99
- 6-16829 060 Command Control Switch-Right Hand \$119.99

072 FASTRACK SWITCHES FEATURE

- 22 ½-Degree turnout
- Removable 1 ¾" extensions
- Length: 15 ¾" straight



REMOTE SWITCH CONTROLLERS SNAP TOGETHER

- C. 6-12049 072 Remote Switch-Right Hand \$103.99
- 6-12048 072 Remote Switch-Left Hand \$103.99
- 6-16826 072 Command Control Switch-Left Hand \$119.99
- 6-16827 072 Command Control Switch-Right Hand \$119.99

072 FASTRACK WYE SWITCHES FEATURE

- 22 ½-Degree wye
- Removable 1 ¾" extensions
- Length: 12"

- D. 6-12047 072 Remote Wye Switch \$96.99
- 6-16832 072 Command Control Wye Switch \$114.99

LIONEL COMMAND CONTROL FASTRACK SWITCHES!

With the same bulletproof design and realistic appearance as our standard FasTrack switches, these can be activated with your CAB-1 or CAB-2 remote controller. Also, multiple command control switches can be programmed to activate in sequence for easy route operation. No ASC or SC-2 accessory is necessary.

With the use of a CAB-1 or CAB-2 remote you gain ultimate control over where your trains are headed and the routes they take to get there.

ALL COMMAND CONTROL SWITCHES FEATURE

- Switches activated with a Command Control CAB-1 or CAB-2 (sold separately)
- Can also be activated by remote lever switch (sold separately)
- Same solid construction, appearance, dimensions as FasTrack remote switches



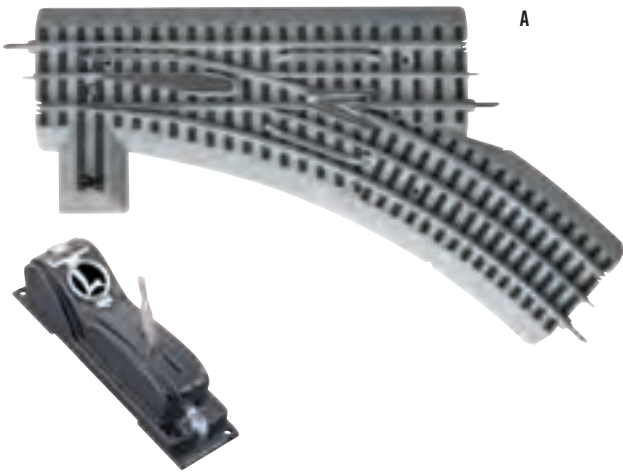

A

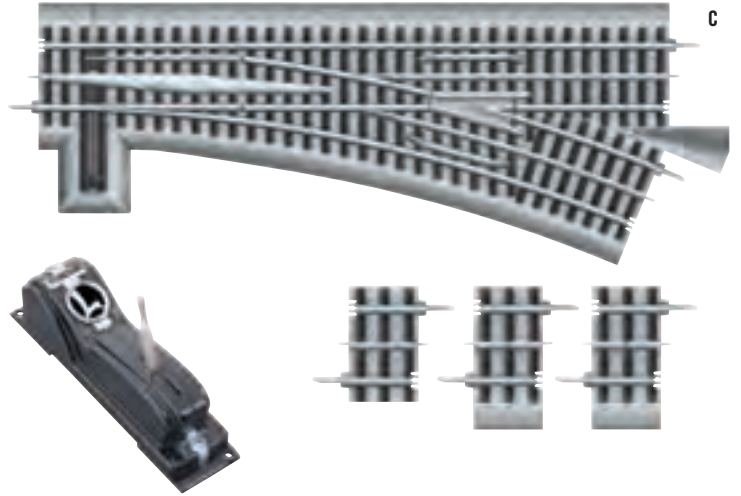

C

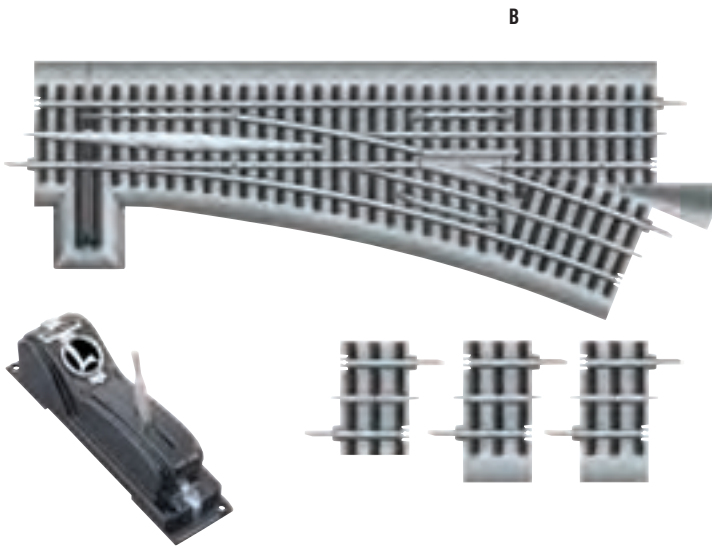

B

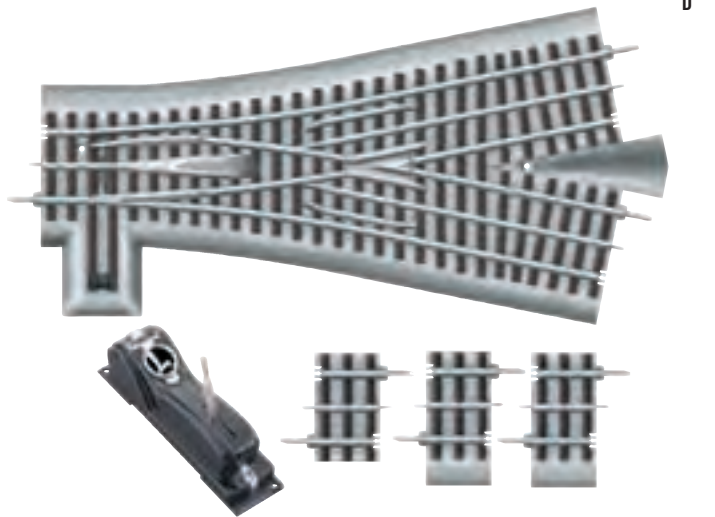

D



Realistic switch lamp

LANTERN BASE IS INTERCHANGEABLE, CAN MOVE TO THE RIGHT OR LEFT SIDE

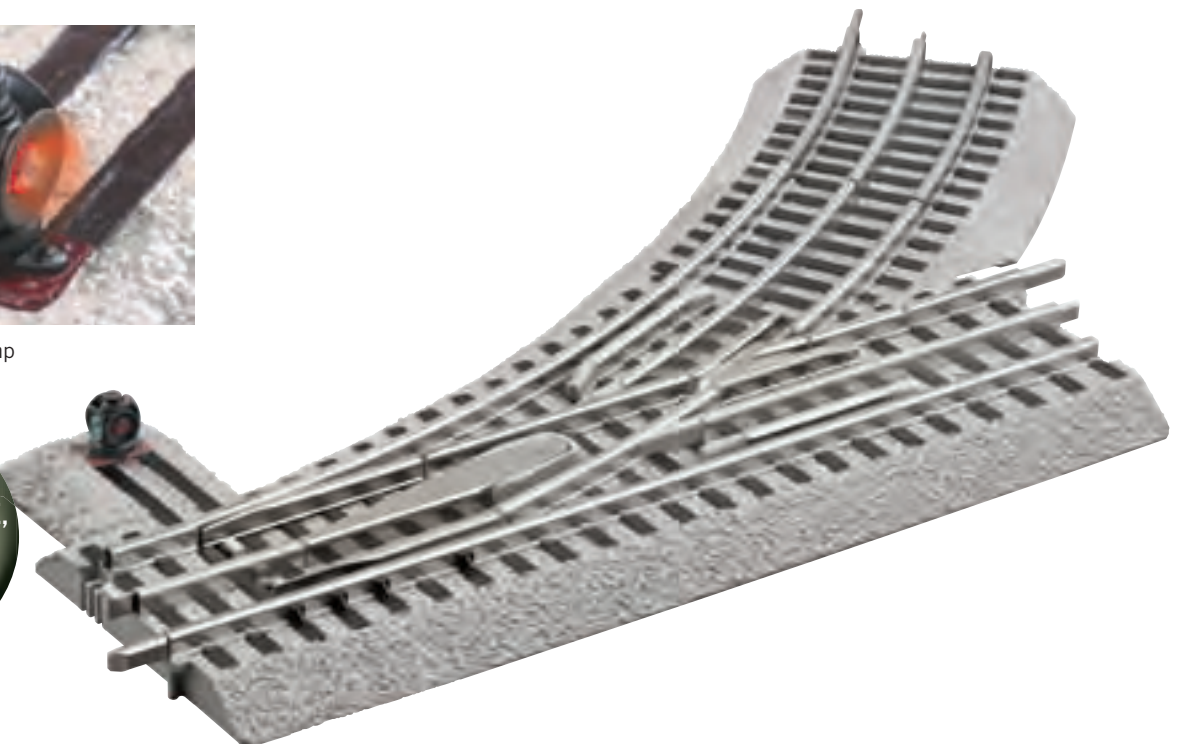

Straight Track



1/2 STRAIGHT TRACK
Length: 4 7/8"
6-65019 \$1.49

STRAIGHT TRACK
Length: 8 3/4"
6-65038 \$1.99

EXTRA-LONG STRAIGHT TRACK
Length: 35"
6-65024 \$5.79



Curved Track



1/2 CURVED TRACK (16 PIECES PER CIRCLE)
Length: 5 1/6"
6-65014 \$1.49

54" DIAMETER CURVED TRACK
(16 pieces per circle)
Length: 14 1/2"
6-65113 \$3.49



27" DIAMETER CURVED TRACK
(8 pieces per circle)
Length: 9 5/8"
6-65033 \$1.99

42" DIAMETER CURVED TRACK
(12 pieces per circle)
Length: 10 7/8"
6-65049 \$3.09

Specialty Track



90-DEGREE CROSSOVER
Length: 7 3/8" x 7 3/8"
6-65020 \$12.29



45-DEGREE CROSSOVER
Length: 10 1/4" x 10 1/4"
6-65023 \$12.29

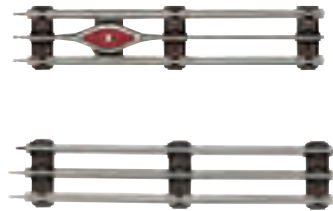

UNCOUPLING TRACK
Length: 8 3/4"
6-65149 \$13.79

INSULATED TRACK
Length: 8 3/4"
6-12841 \$5.99



REMOTE-CONTROL TRACK WITH UCS CONTROLLER
Length: 8 3/4"
6-12746 \$27.99

Switches



27" PATH MANUAL SWITCH
Length: 8 3/4" straight
6-65021 Left Hand \$29.99
6-65022 Right Hand \$29.99



27" PATH REMOTE-CONTROL SWITCH
Length: 8 3/4" straight
6-65121 Left Hand \$49.99
6-65122 Right Hand \$49.99



42" PATH REMOTE-CONTROL SWITCH
Length: 13 5/8" straight
6-65167 Left Hand \$71.99
6-65168 Right Hand \$71.99



A. 0-27 GAUGE TRACK CLIPS

- Keep your 0-27 track sections together with these easy-to-use, slide-on clips
- Perfect for keeping temporary or floor layouts together
- Box of 12

6-62901 \$11.79

STEEL PINS

6-65042 0-27 Gauge \$3.09

FIBRE PINS

6-65041 0-27 Gauge \$3.09

B. UNIVERSAL LOCKON

- Works with 0/0-27 and S

6-24213 \$3.99



90° Crossover



4 Curved Sections

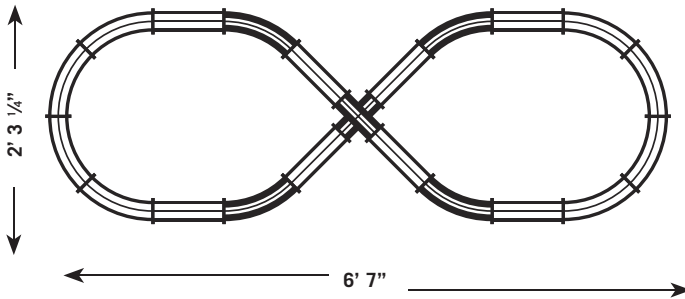

C

C. FIGURE 8 0-27 GAUGE ADD-ON TRACK PACK

Add this track to your oval to create a figure 8 layout. Requires an existing starter set oval of track.

1 - 90-degree crossover 6-65020

4 - pieces curved track 6-65033

6-22966 \$19.99

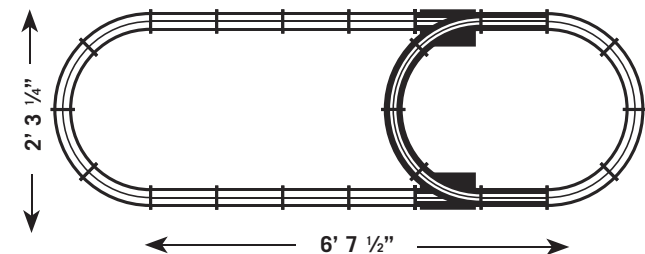
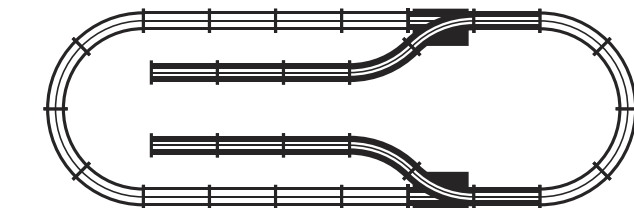
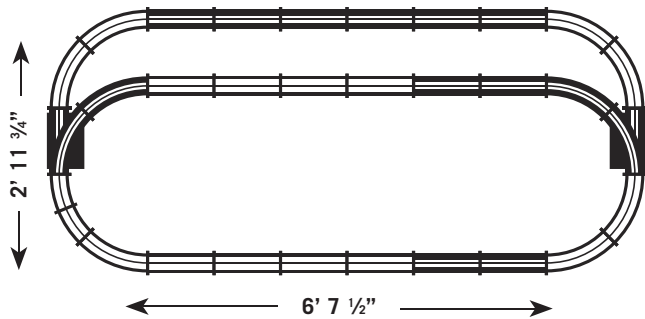

Manual Switch-Right



Manual Switch-Left



2 Curved Sections



10 Straight Sections

DOUBLE-LOOP 0-27 GAUGE ADD-ON TRACK PACK

Add this track to your oval to create a double loop, an oval with two inside sidings, or a double oval. Requires an existing starter set oval of track.

2 - pieces curved track 6-65033

10 - pieces straight track 6-65038

1 - right hand manual switch 6-65022

1 - left hand manual switch 6-65021

6-22967 \$71.99

Straight Track

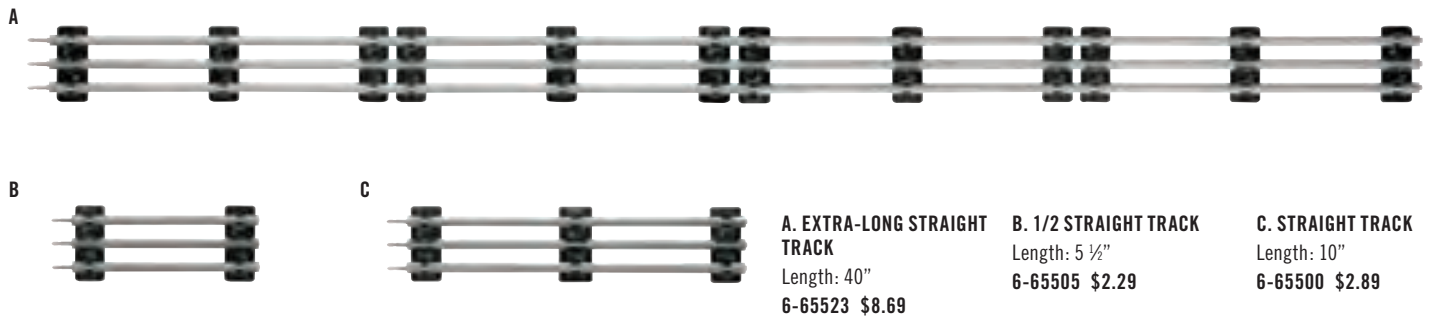

A. EXTRA-LONG STRAIGHT TRACK
Length: 40"
6-65523 \$8.69

B. 1/2 STRAIGHT TRACK
Length: 5 1/2"
6-65505 \$2.29

C. STRAIGHT TRACK
Length: 10"
6-65500 \$2.89

Curved Track

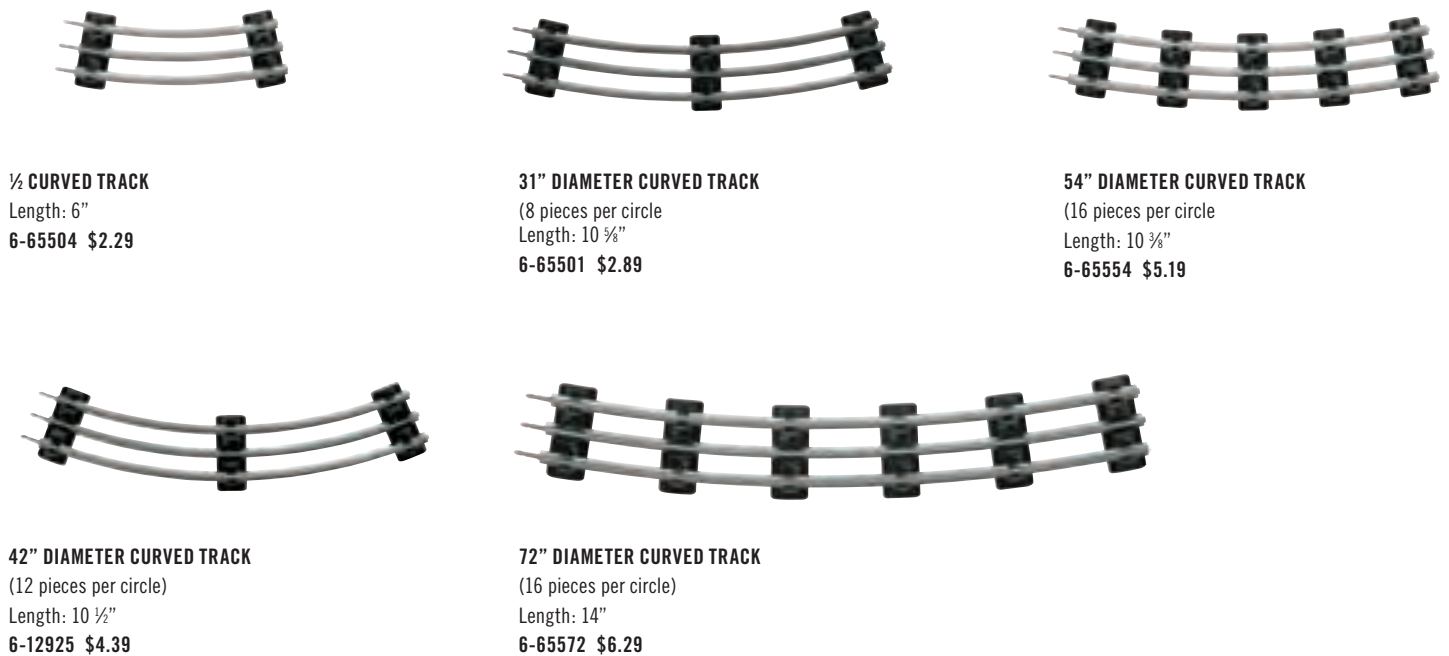

1/2 CURVED TRACK
Length: 6"
6-65504 \$2.29

31" DIAMETER CURVED TRACK
(8 pieces per circle)
Length: 10 3/8"
6-65501 \$2.89

54" DIAMETER CURVED TRACK
(16 pieces per circle)
Length: 10 3/8"
6-65554 \$5.19

42" DIAMETER CURVED TRACK
(12 pieces per circle)
Length: 10 1/2"
6-12925 \$4.39

72" DIAMETER CURVED TRACK
(16 pieces per circle)
Length: 14"
6-65572 \$6.29

Specialty Track



INSULATED TRACK
Length: 10"
6-12840 \$8.99

REMOTE-CONTROL TRACK
Length: 10"
6-65530 \$43.99

45-DEGREE CROSSOVER
Length: 11 3/4" x 11 3/4"
6-65545 \$18.99

90-DEGREE CROSSOVER
Length: 8 5/16" x 8 5/16"
6-65540 \$18.99

Switches



31" PATH REMOTE-CONTROL SWITCH

Length: 10" straight

6-14062 Left Hand \$85.99

6-14063 Right Hand \$85.99



42" PATH REMOTE-CONTROL SWITCH

6-12081 Left Hand \$91.99

6-12080 Right Hand \$91.99



72" PATH REMOTE-CONTROL SWITCH

Length: 14 1/2" straight

6-65166 Left Hand \$139.99

6-65165 Right Hand \$139.99

Deluxe Complete O Gauge Track Pack

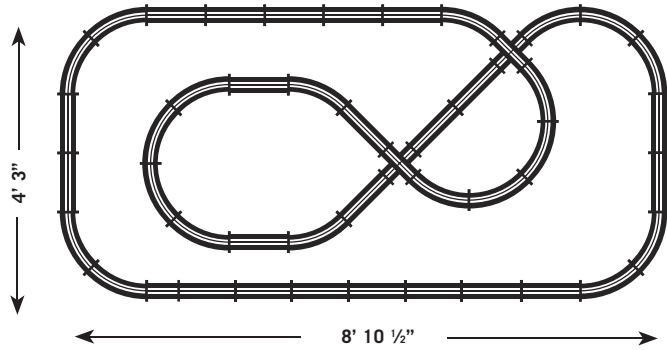

2 90° Crossovers



1 Half Straight Section



20 Curved Sections



22 Straight Sections

DELUXE COMPLETE O GAUGE TRACK PACK

This complete O gauge track set will allow you to create the detailed layout shown. No additional track is required.

20 - pieces curved track 6-65501

2 - 90-degree crossovers 6-65540

22 - pieces straight track 6-65500

1 - half straight 6-65505

6-22969 \$137.99

O Gauge Lockons



LOCKON
6-62900 \$3.99



LIGHTED LOCKON
6-14112 \$7.49



LOCKON WITH WIRES
6-62905 \$7.69



O GAUGE TRACK CLIPS

- Keep your O gauge track sections together with these easy-to-use, slide-on clips
- Perfect for keeping temporary or floor layouts together
- Box of 12

6-12743 \$11.79

STEEL PINS

6-65551 O Gauge \$3.09

FIBRE PINS

6-65543 O Gauge \$3.09



SUPERSTREETS

SuperStreets Sets and Railroadster vehicles for action fun for your layout roadways



A

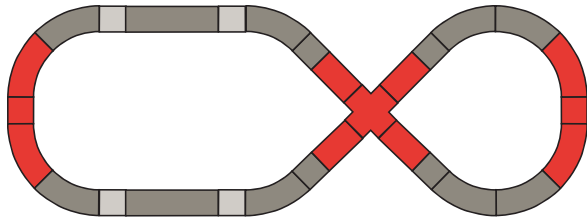

B

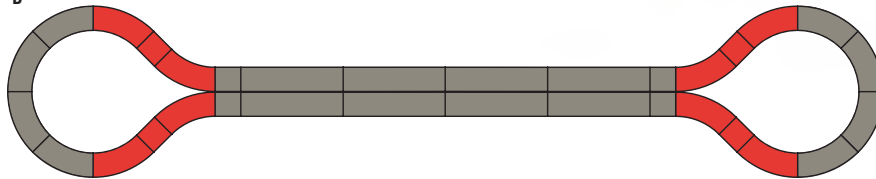

D



E



G



F



A. SUPER STREETS FIGURE 8 EXPANDER PACK

Transforms an oval into a busy intersection

Pack Includes:

- Four D16 Curves, two Curve to Curve Connectors, four 5" Straights, and one Intersection.

6-22264 \$39.99

B. DOGBONE EXPANDER PACK

Transforms an oval into Main Street loop.

Pack Includes:

- Eight D16 Curves and four Curve to Curve Connectors

6-21291 \$29.99

C. LIONEL VAN SUPERSTREETS SET

Everything you need to get rolling with SuperStreets

Set Includes:

- Lionel Railroadster Van
- SuperStreets Roadway for 17" x 52" oval: eight D16 Curves, six 10" Straights and four Straight to Curve Connectors
- Power Pack

6-21698 \$129.99

RAILROADSTERS WITH COMMAND CONTROL

You control speed, lights and braking with the CAB-1 or CAB-2 Throttle

- Control speed and direction
- Turn headlights on or off
- Operating rear brake lights
- Compatible with TMCC & LEGACY Systems
- Conventional control with standard transformer

D. 6-22501 Chicago & North Western Van w/TMCC \$99.99

E. 6-22510 Lionel Step Van w/TMCC \$99.99

MORE RAILROADSTERS FOR SUPERSTREETS

- Conventional control with standard transformer

F. 6-22638 PRR Crew Bus \$44.99

G. 6-22517 Quick Lane Ford™ Motorcraft® Auto Parts Van \$41.99

©2009 Ford Motor Company.

H. 6-22637 Quikrete™ Step Van \$47.99

©2009 QUIKRETE®. All rights reserved.

NEW



H



ROADWAY SIGNS

FOR SUPERSTREETS OR ANY LAYOUT ROAD

I. WARNING PACK

- Signs fit into resin base
- 2 Deer Crossing
- 2 School Crossing
- 2 Children Playing
- 2 Pedestrian Crossing
- 2 Slippery When Wet
- 1 Farm Equipment
- 1 Bike
- 12 Natural Bases

6- 21721 \$24.99

- Signs fit into resin base
 - 4 Stop
 - 2 55 Speed Limit
 - 2 35 Speed Limit
 - 1 Emergency Stopping Only
 - 1 Do Not Pass
 - 1 No Left Turn
 - 1 No Parking
 - 12 Natural Bases
- 6-21730 \$24.99



Railroad Crossing Pack includes base insets for SuperStreets Tubular Track Grade Crossing – perfect for any warning sign. See page 134-345.

J. RAILROAD CROSSING PACK

- Signs fit into resin base or inserts for SuperStreets Grade Crossing
- 2 RR Crossbucks
- 2 RR Advanced Warning
- 2 Do Not Stop on Tracks
- 6 Natural Bases
- 2 SuperStreets Grade Crossing Inserts

6-21738 \$21.99

K. REGULATORY PACK



G



I



J

SUPERSTREETS™ ROADWAY

Straight Roadway Sections

A. 10" STRAIGHT

6-21431 \$3.19

Also available

6-21434 8-Pack \$23.99

6-21571 10" Insulated
Roadway Section Two
Pack \$9.99

**C. 2.5" STRAIGHT –
STRAIGHT TO CURVE
CONNECTOR 4-PACK**

Tapered flange grooves
to connect a straight and
curved roadway

6-21261 \$11.99

B. 5" STRAIGHT 4-PACK

6-21433 \$15.99

**2.5" STRAIGHT ROADWAY
4-PACK**

6-22566 \$11.99

**2.5" STRAIGHT – CURVE
TO CURVE CONNECTOR
4-PACK**

Wide flange grooves to
connect any two curved
roadways

6-21282 \$11.99

**D. ADJUSTABLE STRAIGHT
KIT**

Includes:

- Two adjustable straight road beds
- Two end cap pieces
- Four rails (4)
- Four outer and two center connector pins

6-22598 \$21.99

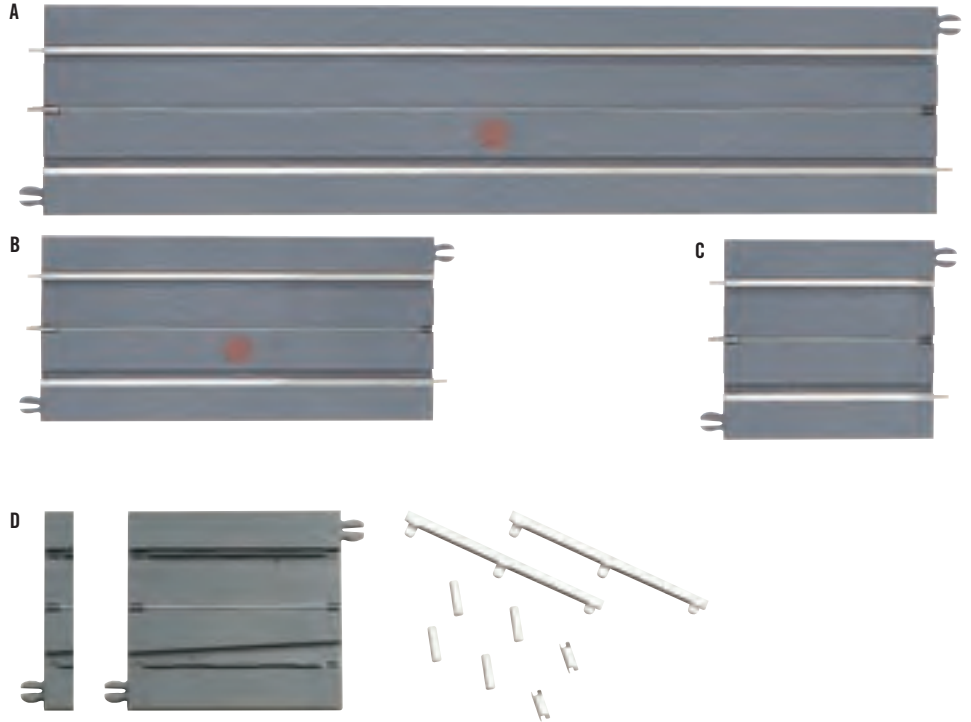

Marked Roadway Section

E. SCHOOL 5" STRAIGHT 2-PACK

6-21572 \$12.99

F. CROSSWALK 5" STRAIGHT 2-PACK

6-21574 \$12.99

**G. STOP AHEAD 5" STRAIGHT
2-PACK**

6-21573 \$12.99

**H. RAILROAD XING 10" STRAIGHT
2-PACK**

6-21575 \$14.99

I. SKID MARK ROADWAY PACK

Includes:

- Two 10" Straights
- One D16 Curve
- One D21 Curve

6-21576 \$19.99

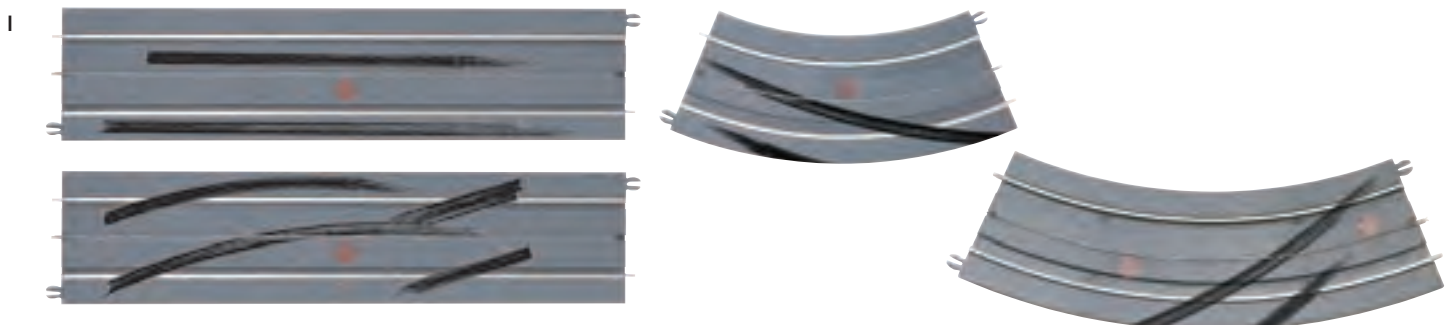
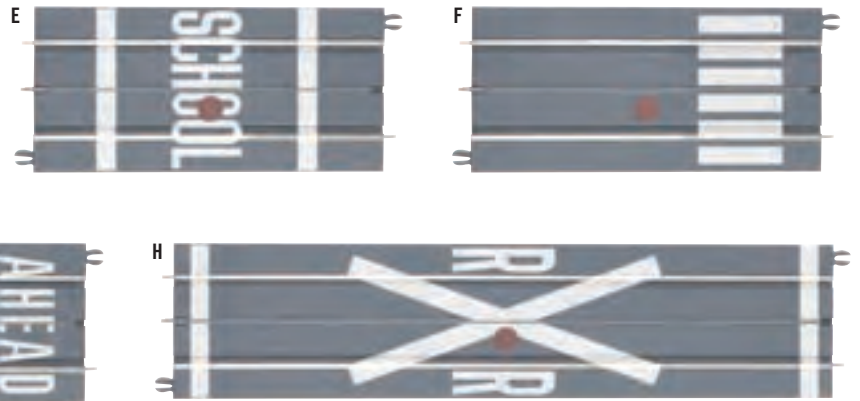

Curved Roadway Sections

J. D16 CURVE

(8 pieces per 16" diameter circle)

6-21430 \$3.19

Also available

6-21432 8-Pack \$23.99

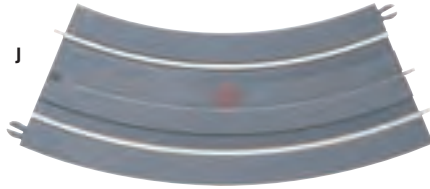

K. D21 CURVE

(8 pieces per 21" diameter circle)

6-21281 \$3.49

D16 curves nest inside D21 curves for realistic two way traffic.

Specialty Roadway Sections

L. INTERSECTION

6-21286 \$11.99

Also available

6-21266 Intersection

4-Pack \$43.99

M. FASTRACK GRADE

CROSSING

6-21163 \$26.99

N. TUBULAR TRACK GRADE

CROSSING

6-21283 \$24.99

O. 10" TRANSITION TO

FASTRACK

6-21164 \$11.99

Also available

6-21165 10" Transition to

FasTrack 2-Pack \$21.99

10" TRANSITION TO

TUBULAR TRACK

6-21284 \$9.99

Also available

6-21285 10" Transi-

tion to Tubular Track

2-Pack \$16.99

R. Y ROADWAY

6-21287 \$16.99

Q. SUPERSTREETS BAR-

RICADE 2-PACK

Perfect for each end of a

trolley line.

6-22379 \$13.99

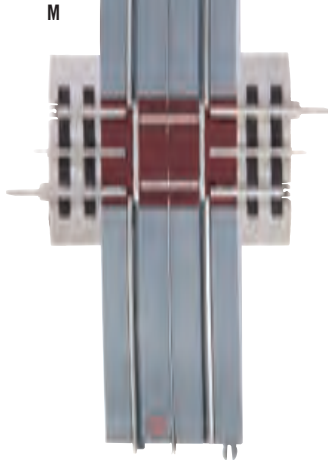
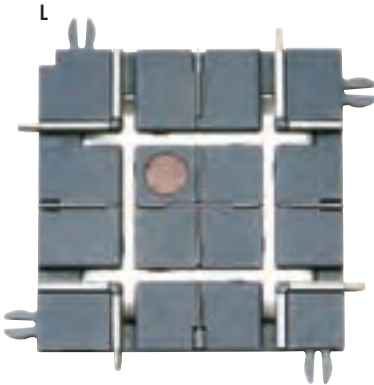
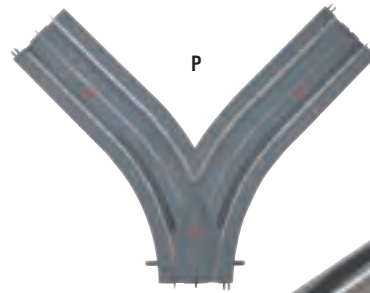
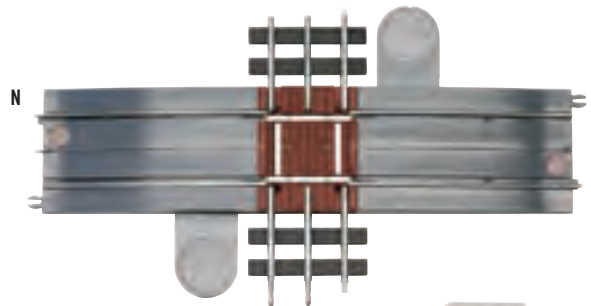

Realistic manhole covers hide all screw holes.

Guard Rails

R. SUPERSTREETS 10" STRAIGHT

GUARD RAIL 2-PACK

6-22470 \$20.99

Also Available:

6-22534 SuperStreets D16 Curve

Guard Rail 2-Pack \$20.99

6-22536 SuperStreets D21 Curve

Guard Rail 2-Pack \$22.99

Also Available:

6-21288 0 Gauge Conversion

Pins (8 Outer / 4 Center) \$2.19

6-21289 SuperStreets Connector

Pins (8 Outer / 4 Center) \$3.19

6-21290 Hookup Wires (2) \$3.79

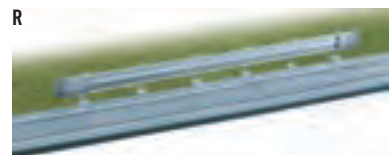

Roadway not included



Detail

LIGHTS! CLOWNS! FUN!

A. RINGLING BROS.™ EXPANSION PACK

- Pack Includes:
- Stock car with bobbing horses
- Gondola with crates
- Tiger cage car
- Four FasTrack 10" straights
- Minimum Curve: 0-27

6-22126 \$149.99

- Operating die-cast couplers
 - Minimum Curve: 0-31
 - Length: 13½"
- 6-22635 \$59.99

C. RINGLING BROS.™ SPEEDER CHASE SET (POWERED & DUMMY)

- Transformer controlled forward neutral and reverse operations
 - Die-cast body
 - Operating headlight
 - Blinking roof light
 - Detailed clown figures
 - Minimum Curve: 0-27
 - Length: 4" (plus bumper)
- 6-22222 \$91.99

D. RINGLING BROS.™ OPERATING BILLBOARD

- Illuminated
 - Worker smoothes billboard
 - Authentic contemporary Ringling Bros. graphics
 - Dimensions: 8½" x 4"
- 6-22679 \$99.99

- Trailer connecting bar
 - Minimum Curve: 0-27
 - Length: 4" (plus bumper)
- 6-22563 \$69.99

RINGLING BROS. AND BARNUM & BAILEY and THE GREATEST SHOW ON EARTH are trademarks of and are used under license from Ringling Bros.-Barnum & Bailey Combined Shows, Inc.
RINGLING BROS. IMAGES, LOGOS, AND MARKS
©2009 FELD ENTERTAINMENT
www.Ringling.com

B. RINGLING BROS.™ OPERATING DUAL SEARCHLIGHT CAR W/GENERATORS

- Rotating searchlights
- Die-cast trucks

E. RINGLING BROS.™ HANDCAR AND TRAILER SET

- Powered hand car
- Two roller pickups
- Detailed clown figures
- Wood planking and tool box detail

3-PACK

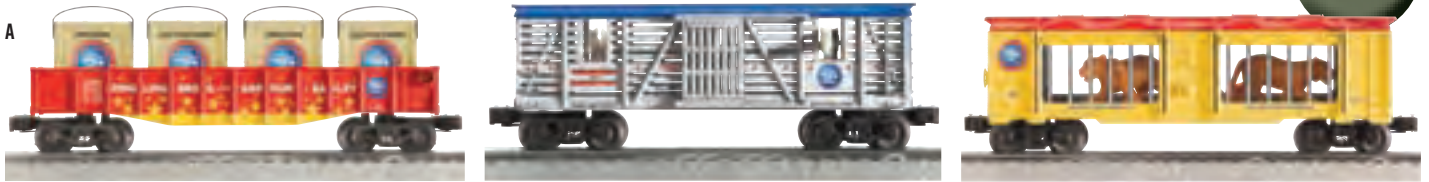

Speeders bounce off each other when they collide on the track!



D

NEW



NEW

E

RINGLING BROS. AND BARNUM & BAILEY

THE GREATEST SHOW ON EARTH™ TRAVELS BY TRAIN

A-D RINGLING BROS. HEAVYWEIGHT CARS

During the first half the 20th century Ringling Bros. performers and crew crisscrossed the country in a fleet of red coaches, including the Michigan and Minnesota. The palatial JOMAR private car, with living room, staterooms, bathroom, dining room, kitchen, and quarters for a chef and butler was part of the consist, as an always-ready home for it's name sakes, John and Mable Ringling. Advertising cars traveled in advance of the circus as both the home and office of the promotions department. Our Advertising Car #2 wears the design of the last heavyweights to serve as advertising cars, through the end of World War II.

- Interior Streamlighting®
- Detailed interiors with passengers
- Vestibules with opening doors
- Metal steps & grab rails
- Metal chassis with underside details
- 6-Wheel die-cast trucks
- Operating die-cast couplers
- Diaphragms included

- End marker lights on observation car
- Minimum Curve: Swing Steps for 0-31 Operation
- A. 6-22672** Ringling Bros.™ 18" Heavyweight Sarasota Private Observation Car **\$145.99**
- B. 6-22225** Ringling Bros.™ 18" Heavyweight JOMAR Private Car **\$145.99**
- C. 6-21688** Ringling Bros.™ Heavyweight Michigan and Minnesota Coach 2-Pack **\$289.99**
- D. 6-22634** Ringling Bros.™ 1938-46 18" Heavyweight Advertising Car No 2 **\$145.99**

E-I RINGLING BROS. ALUMINUM CARS

After World War II, Ringling Bros. added modern streamlined cars, many acquired from the Union Pacific. The 63002 Shop Car and 40003 Coach joined the red unit train in 1972; the 40010 Coach was added 1987 and the 63005 Generator Car in 1994. The Aluminum Advertising Car is inspired by the design of Ringling Bros.' last advertising car, retired in the 1950s.

- Interior StreamLighting®
- Vestibules with opening doors

- Extruded aluminum body
- Metal grab rails
- Metal chassis with underside details
- 4-Wheel die-cast trucks w/separate springs
- Operating die-cast couplers
- Diaphragms included
- Minimum Curve: 0-42 with removable steps for 0-31 operation
- E. 6-22633** Ringling Bros.™ 18" Aluminum Coach #40003 **\$179.99**
- F. 6-22255** Ringling Bros.™ 18" Aluminum Coach #40010 **\$179.99**
- G. 6-22625** Ringling Bros.™ 18" Aluminum Car #63005 **\$179.99**
- H. 6-22257** Ringling Bros.™ 18" Aluminum Shop Car #63002 **\$179.99**
- I. 6-22628** Ringling Bros.™ 18" Aluminum Advertising Car No 2 **\$179.99**



NEW



D



E



F

NEW



G

NEW



H

NEW



I

THE MOST COLORFUL CARGO ON RAILS

A,B. FLAT CARS

- Vintage posters from the Ringling Bros. archive
- Wagon loading ramps
- Fully sprung die-cast trucks
- Operating die-cast couplers
- Length: 13½"
- Minimum: Curve: 0-31

A. 6-22654 Ringling Bros.™ Flat Car #46 w/3 Circus Wagons \$59.99

B. 6-22656 Ringling Bros.™ Flat Car #66 w/3 Circus Wagons \$59.99

C. RINGLING BROS.™ SCALE STOCK CAR #52

- Fully sprung die-cast trucks
- Operating die-cast couplers

- Separate metal ladders and grab rails
- Separate metal brake wheel
- Stainless steel roofwalk and landing pads
- Metal chassis with underside detailing
- Opening doors with metal door runners
- Length: 11½"
- Minimum Curve: 0-31

6-22629 \$59.99

D,E. OPERATING CARS

- Fully sprung die-cast trucks
- Operating die-cast couplers
- Operates with any UCS Track or 6-21438 Remote Controller
- Die-cast chassis on dump car
- Lift-up platform and fold-down stakes on dump car

- Length: 11½" Boxcar
- 12" Dump Car
- Minimum Curve: 0-31

D. 6-22645 Ringling Bros.™ Operating Tent Pole Dump Car \$129.99

E. 6-22642 Ringling Bros.™ Scale Large Animal Operating Feed Car \$149.99

F. RINGLING BROS.™ LIGHTED CLOWN SCALE WOOD-SIDED REEFER #48

- Blinking LED clown nose
- Fully sprung die-cast trucks
- Operating die-cast couplers
- Separate metal grab rails
- Metal chassis with underside detailin
- Separate metal ladders

- Separate metal brakewheel
- Length: 11½"
- Minimum Curve: 0-31

6-22627 \$89.99

G. RINGLING BROS.™ TRACTOR TRAILER #5

- Die-cast chassis and roof
- Painted running lights
- Length: 13½"

6-22630 \$34.99

H. RINGLING BROS.™ GOLD UNIT REPLICA TRACTOR W/CONTAINER ON CHASSIS

- Replica of current Gold Tour truck graphics
- Die-cast chassis and cab
- Removable container – usable on flat cars
- Length: 13½"

6-22555 \$54.99



NEW



C

NEW



D

NEW



E

NEW



F



NEW

G



H

FORD MOTOR COMPANY

Henry Ford's vision of the continuous moving assembly system was fully realized at the River Rouge plant where a 130 mile railroad moved 1,500 tons of iron and 500 tons of glass daily – and completed a new car every 49 seconds.



A



A. FORD™ WATER TOWER W/LIGHT

- Working warning light
 - Dimensions: 4.5" x 4.5" base
- 6-22673 \$26.99

B. RAILROAD WATER TOWER W/VINTAGE FORD MOTOR COMPANY LOGO

6-22504 \$24.99

C. FORD™ SPEEDER #12

- Transformer controlled forward, neutral and reverse operation
 - Die-cast body
 - Operating headlight
 - Blinking roof light
 - Detailed figures
 - Minimum Curve: 0-27
 - Length: 4"
- 6-22646 \$74.99

D. QUICK LANE FORD™ MOTORCRAFT® AUTO PARTS VAN

- Conventional control with standard transformer
- 6-22517 Quick Lane Ford™ Motorcraft® Auto Parts Van \$41.99

E. FORD™ MOTORCRAFT® 48' MODERN ALUMINUM TANK CAR

- Fully sprung die-cast trucks
 - Operating die-cast couplers
 - Die-cast chassis
 - Prototypical metal brake details
 - Separate die-cast grab rails and ladders
 - Prototypical catwalk
 - Die-cast drain details
 - Diamond warning markers
 - Minimum Curve: 0-31
 - Length: 12"
- 6-22644 \$94.99

F. FORD™ MOTORCRAFT® TRAILER ON BNSF SCALE FLAT CAR

- Fully sprung die-cast trucks
 - Operating die-cast couplers
 - Opening door
 - Minimum Curve: 0-31
 - Length: 13½"
- 6-22539 \$59.99

G. FORD™ MP-15 DIESEL

- Dual motors
 - Transformer controlled forward, neutral and reverse operation
 - Diesel horn
 - Operating headlight
 - Cab light
 - Metal chassis and handrails
 - Operating couplers
 - Minimum Curve: 0-27
 - Length: 12"
- 6-22643 \$134.99



B

NEW



C



D

NEW



E



F

NEW



G

NAPA VALLEY WINE TRAIN

At night the Napa Valley Railroad hauled freight to various valley operations, but since 1987 the handsome Napa Valley Wine Train rules the rails from dawn past dusk. The K-Line by Lionel version is led by accurate replica of their burgundy, gold and green fully restored Alco FAs. In the meticulously restored heavyweight passenger cars, riders enjoy gourmet dining, exceptional wines from local wineries, and the spectacular Napa Valley scenery. The excursion train never turns around – just switches the Alcos to the other end – so the consist is always made up with an observation car at each end.

A. NAPA VALLEY WINE TRAIN ALCO FA AA DIESEL W/HORN

- Dual motors in operating A unit
- Transformer controller forward, neutral, and reverse operation
- Operating headlight
- Cab light
- Diesel horn
- Metal grab rails
- Detailed Alco trucks with operating couplers
- Diaphragms included
- Minimum Curve: 0-27
- Length: 21" AA Combined Length

6- 22610 \$229.99

B. NAPA VALLEY WINE TRAIN 15" HEAVY-WEIGHT PASSENGER CAR 4-PACK

Pack Includes

Le Chef De Cuisine Diner #1090, Le Petit Gourmet Diner #1015, Chardonnay Observation #1018, and Cabernet Sauvignon Observation #1011

Features

- Interior StreamLighting®
- Detailed interiors with passengers
- Vestibules with opening doors
- Metal steps & grab rails
- Metal chassis with underside details
- 6-wheel die-cast trucks
- Operating die-cast couplers
- Diaphragms included
- End marker lights on observation cars
- Minimum curve: 0-31

6- 22613 \$449.99



4-PACK



B



ALL ITEMS
NEW



A



B





LOCOMOTIVES

A. PENNSYLVANIA STREAMLINED K-4 PACIFIC & DIE-CAST TENDER

The Broadway Limited was synonymous with speed, luxury and style, never more so than the decade from 1938 to 1948 when Raymond Loewy's streamlined tuscan and gold design was worn by the K-4 and a new passenger fleet.

- **Command Control** equipped – able to run in Command Control Mode or in Conventional Transformer Control Mode
- **RailSounds** sound system with CrewTalk and TowerCom
- **ElectroCoupler** on rear of tender
- Operating headlight
- Smoke unit with on/off switch
- Directional lighting
- Illuminated marker lights and firebox
- Detailed cab interior
- Engineer figure
- Die-cast boiler and tender
- Separate metal grab rails and steps
- 6-Wheel die-cast trucks on tender
- Rear directional light on tender
- Minimum Curve: 0-31
- Combined Length: 21"

6-22402 \$499.99

B. SOUTHERN MP-15 PAIR (DUMMY AND POWER UNIT)

Like many railroads the Southern ran MP-15s in pairs to get more power and extend the life of these workhorses. The Southern's were dressed in their classy tuxedo livery.

Powered Unit Features

- Dual motors
- Transformer controlled forward, neutral, and reverse operation
- Diesel horn
- Operating headlight
- Cab light

Both Units Feature

- Metal chassis and handrails
- Operating couplers
- Minimum Curve: 0-27
- Length: 12" each

6-21693 \$199.99

Also Available

PENNSYLVANIA 18" BROADWAY LIMITED ALUMINUM PASSENGER CAR 4-PACK

Pack Includes:

#4001 Coach, 4501 Diner, Imperial Park Pullman, and Metropolitan View Observation Car

6-22433 \$599.99

PENNSYLVANIA 18" BROADWAY LIMITED ALUMINUM PASSENGER CAR 2-PACK

Pack Includes:

Imperial View Pullman and #6529 Baggage Mail

6-22420 \$299.99

See www.lionel.com for images and passenger car features.

C. B&O BOXCAB DIESEL LOCOMOTIVE

- Transformer controlled forward, neutral, and reverse operation
- Operating horn
- Directional headlights
- Cab detail with engineer figure
- Separate metal grab rails and ladders
- Operating die-cast couplers
- Minimum Curve: 0-27
- Length: 7¾"

6-22639 \$99.99

D. NEW HAVEN DIE-CAST PLYMOUTH SWITCHER WITH SNOW PLOW

Ready for winter with an all-new snowplow!

- Transformer controlled forward, neutral, and reverse operation
- Directional lighting
- Operating smoke unit
- Engineer figure

- Die-cast body
- Separate metal grab rails and ladders
- Operating die-cast scale couplers
- Gauge couplers included
- Minimum Curve: 0-27
- Length: 5½"

6-22624 \$159.99

E. STAR SPANGLED GG-1 ELECTIRC

- Transformer controlled forward, neutral, and reverse operation
- Dual vertical motors
- Operating headlight
- Illuminated marker lights
- Die-cast body
- Metal chassis & handrails and grab rails
- Prototypical ladders and doors
- Working pantographs
- Minimum Curve: 0-31
- Length: 14½"

6-21701 \$259.99



NEW



C

NEW



D



E

NEW



21" PASSENGER CARS

ALL ALUMINUM PASSENGER CARS ON PAGES 148-149 FEATURE:

- Interior StreamLighting®
- Detailed interiors with passengers
- Vestibules with opening doors
- Extruded aluminum car body
- Metal chassis with underside details
- Metal grab rails
- 4-Wheel die-cast trucks w/separate springs
- Operating die-cast couplers
- Diaphragms included
- Tinted windows on Mountain View
- Minimum Curve 21" Cars: 0-54
- Minimum Curve 18" Business Car: 0-42 with front swing skirts for 0-31 operation at end of train

A-B GREAT NORTHERN BIG SKY BLUE CARS

When the Great Northern began to modernize its image in 1967, they began re-painting the classic Pullman Green and Omaha Orange fleet Big Sky Blue and integrating the newly decorated cars into the flagship runs like the Empire Builder.

A. 6-22423 Great Northern 21" Big Sky Blue Aluminum Passenger Car 2-Pack **\$359.99**

Includes: #1323 Vista Dome and Mountain View Great Dome

B. 6-22533 Great Northern 21" Aluminum Pullman Pullman #1377 **\$179.99**

C-E MILWAUKEE ROAD YELLOW & GREY CARS

The Milwaukee had a visual makeover, too. As it consolidated passenger operations with the Union Pacific, the traditional Milwaukee Road orange was replaced by UP yellow, red, and gray. In any color, their Sky Top observation car may have been the most spectacular passenger car ever built.

C. 6-22674 Milwaukee Road 21" Aluminum Passenger Car 2-Pack **\$399.99**

Includes: #122 Diner and Alder Creek Sky Top Observation Car

D. 6-22439 Milwaukee Road 21" Aluminum Passenger Car 2-Pack **\$359.99**
Includes: #59 Super Dome and Red River Valley Parlor Car

E. 6-22530 Milwaukee Road 21" Aluminum Coach #627 **\$179.99**

F. SANTA FE BLACK MESA 18" ALUMINUM BUSINESS CAR

The black and red Midnight Chief is all fantasy but so striking. If only life would imitate art.

6-21703 **\$159.99**



NEW



2-PACK



D



E



F

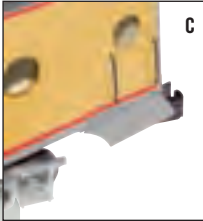

C

2-PACK



THE PAOLI LOCAL

The most famous of all suburban commuter lines, the Paoli Local brought Philadelphia society to Center City from their Main Line suburbs.



A-B. PRR PAOLI LOCAL MU CARS

Through both summer and winter – seersucker suits or cashmere scarves – the line was so popular with mainline business commuters that in 1915, the Pennsylvania electrified 20 miles of track and introduced MU operation, cars that were modified P-54 steam suburban coaches. Noted for the unique look of their round owl eye windows in the vestibules, the MP-54s operated both as coaches and combination Passenger-Baggage MUs.

- Dual truck mounted motors (powered unit)
- Transformer controlled forward neutral and reverse operations
- Transformer
- Operating headlight and marker lights
- Authentic PRR paint scheme and lettering pattern
- Interior StreamLighting®
- Detailed interiors with passenger figures
- Working pantographs
- Separate metal grab rails & steps
- Metal chassis with underside details
- Metal safety chains at end
- 4-Wheel die-cast trucks
- Minimum Curve: 0-31
- Length: 15" per unit

A. 6-22619 PRR Paoli Local 15" Interurban MP54 MU Commuter Train 2 Pack (powered & dummy) **\$289.99**

B. 6-22622 PRR Paoli Local 15" Interurban MPB54 Motorized Combine **\$199.99**

C. PENNSYLVANIA COMMUTER TRAIN STATION

Your Paoli Local can serve commuters at a typical suburban station. Included is a selection of stations signs for traditional Main Line station stops. Even the station advertising trumpets authentic Philadelphia institutions.

- Stickers with the names of 17 real suburban station stops
- Ramp included

6-22623 \$34.99



A

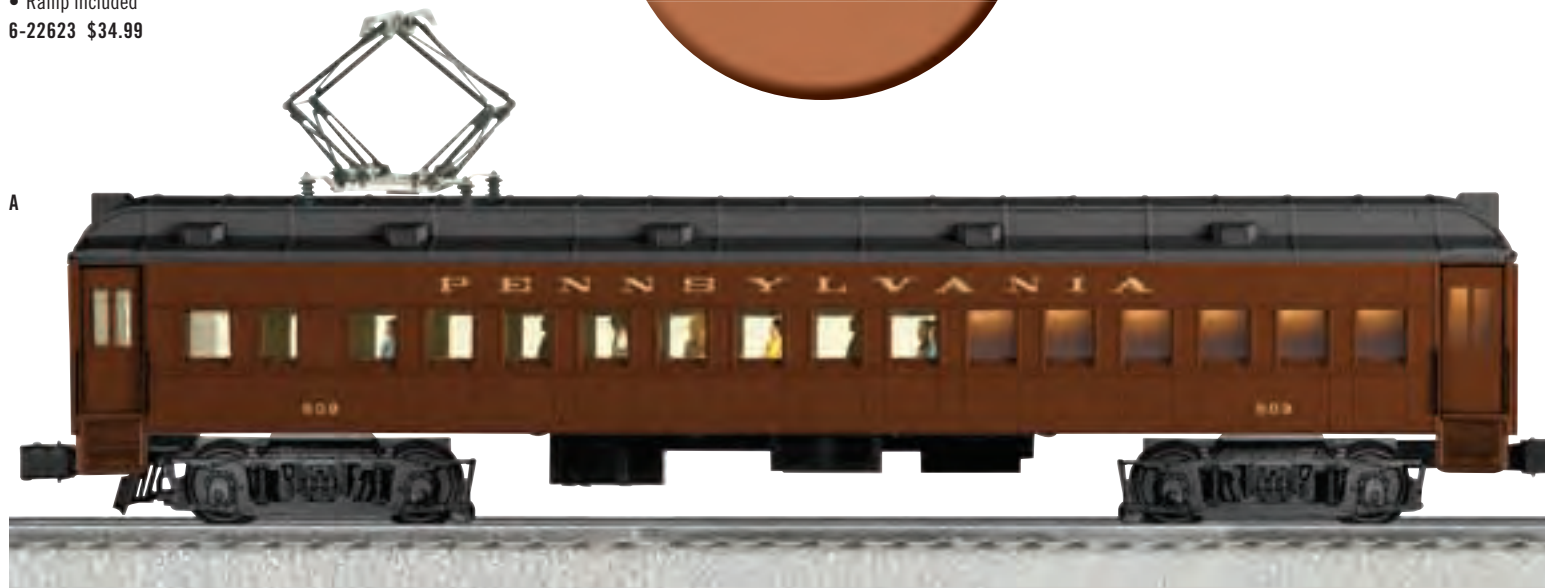

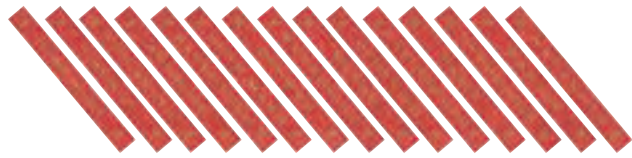

C



B

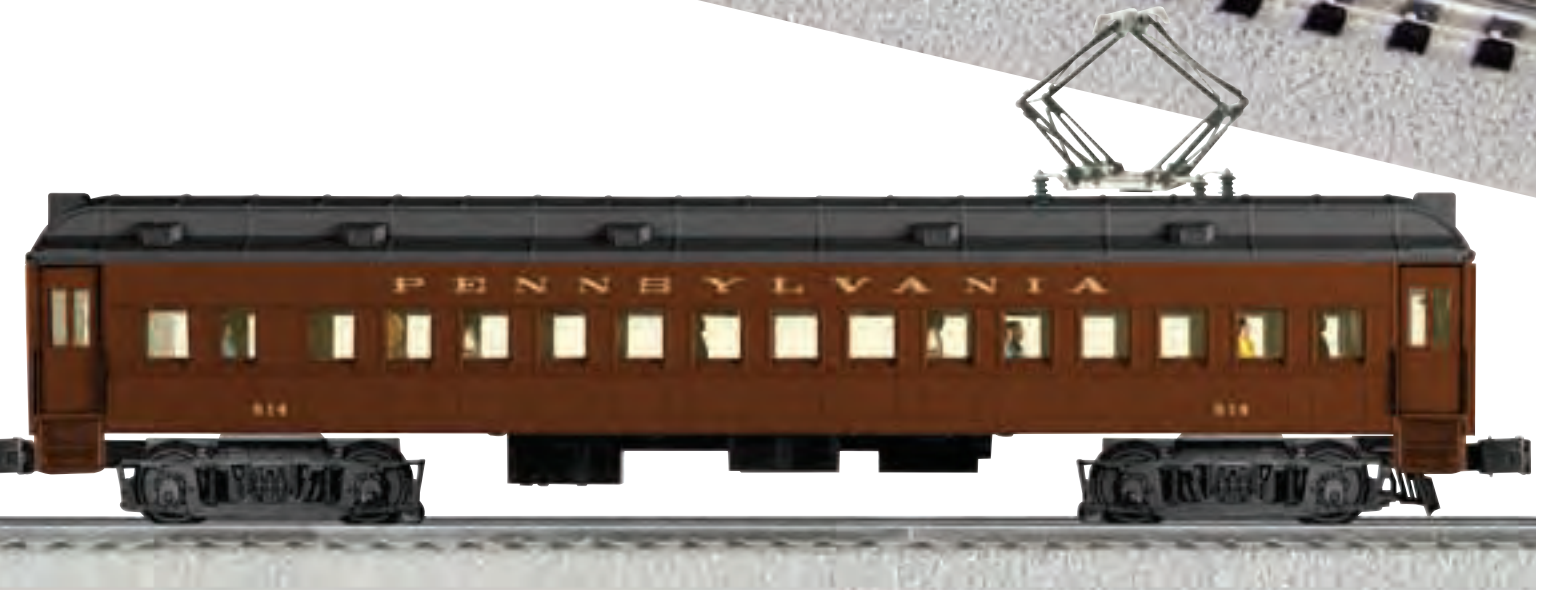

SCALE FREIGHT

All Scale Freight Cars Feature

- Fully sprung die-cast trucks
- Operating die-cast couplers
- Minimum Curve: 0-31

A,B. STOCK CARS AND BOXCARS

- Separate metal ladders and grab rails
- Separate metal brake wheel
- Stainless steel roofwalk and landing pads
- Metal chassis with underside detailing
- Opening doors with metal door runners
- Length: 11½"

A. 6-22528 Great Northern Stock Car \$54.99

B. 6-22527 Toledo Peoria & Western Boxcar \$54.99

C. UNION PACIFIC DIE-CAST GONDOLA WITH FREIGHT KIT

- Die-cast metal body
- Prototypical metal grab rails
- Separate metal brakewheel
- Kit Includes: Three covers, two bulkheads and 6-piece high side set
- Length: 14"

6-22559 \$79.99



NEW



D, E. OPERATING CARS

- Operates with any UCS Track or 6-21438 Remote Controller
- Die-cast chassis (Dump Car)
- Lift-up platform & fold-down stakes (Dump Car)
- Length: 11½" Boxcar
- 12" Dump Car

D. 6-21708 Canadian National Operating Log Dump Car \$119.99

E. 6-22670 Santa Fe Operating Boxcar \$139.99

F. REMOTE CONTROLLER

6-21438 \$34.99

G. DUMP BIN

6-21355 \$22.99



NEW



H. ROMA WINE CO. WOOD-SIDED BILLBOARD REEFER

- Separate metal ladders and grab rails
- Separate metal brake wheel
- Opening roof hatches
- Metal chassis with underside detailing
- Opening doors
- Length: 11½"

6-22519 \$69.99



H

I. NEW HAVEN 16-WHEEL DEPRESSED CENTER FLAT CAR WITH TRANSFORMER

- Die-cast metal body
- Separate metal steps and grab rails
- Load secured with working chains
- Length: 15"

6-22668 \$84.99

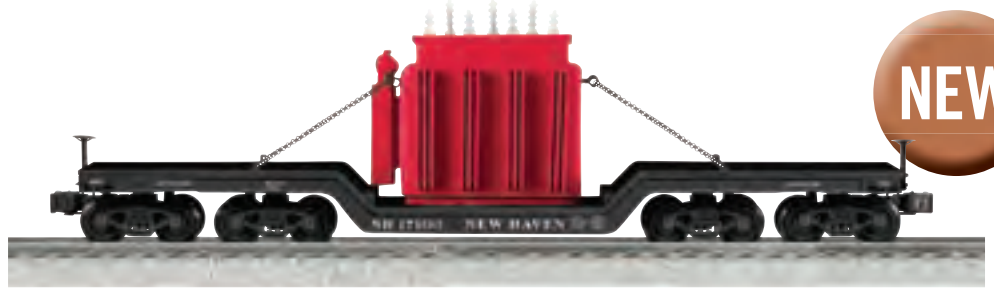

I

J. BURLINGTON WOOD-SIDE GONDOLA WITH SPOOL LOAD

- Die-cast metal body
- Prototypical metal grab rails
- Separate metal brakewheel
- Removable covers
- Detailed wood plank floor
- Length: 13½"

6-22560 \$59.99



J

K. SOUTHERN BAY WINDOW SMOKING CABOOSE

- Interior StreamLighting®
- Operating marker lights
- Smoke unit with On/Off switch
- Furnished interiors with conductor and brakemen figures
- Bronze bathroom vent and radio antenna
- Separate steel grab rails
- Separate metal ladders and brake wheels
- Fully sprung opening doors
- Stainless steel landing platform
- Metal chassis with underside detail
- Metal safety chain
- Length: 10½"

6-22671 \$89.99



K

L. SEABOARD DIE-CAST HOPPER WITH GRAVEL LOAD

- Spring-loaded opening drop doors
- Separate metal ladders and grab rails
- Die-cast brake wheel and air tank
- Length: 11½"

6-22450 \$79.99



L

O GAUGE FREIGHT

Gondolas, Hoppers, Tank Cars and Caboose

O GAUGE FREIGHT CARS

- Die-cast trucks
- Operating die-cast couplers
- Minimum Curve: 0-27

A. 6-22647 Rock Island Gondola \$34.99

B. 6-22648 PRR Gondola \$34.99

C. 6-22661 Western Maryland 2-Bay Covered Hopper \$34.99

D. 6-22618 Signal Oil Company Single Dome Tank Car \$39.99

E. 6-22659 Union 76 Single Dome Tank Car \$39.99

F. NEW HAVEN ILLUMINATED CABOOSE

- Die-cast trucks
- Operating die-cast couplers
- Interior illumination
- Minimum Curve: 0-27

6-22663 \$39.99





D



E



F

O GAUGE FREIGHT

A, B. SPECIAL ADDITION BOX CARS

Three ways to commemorate the newest rail-roader in the family:

- Write a message on the smooth door
- Put the baby's vital statistics on enclosed sticker that fits the door
- Attach your favorite photos (trace sticker for size)

- A. 6-21359 Special Addition
It's A Boy Boxcar **\$39.99**
- B. 6-21358 Special Addition
It's A Girl Boxcar **\$39.99**

A



B



RENEWABLE ENERGY

H. KBL WIND TECHNOLOGIES CORP. OPERATING WIND TURBINE

Add a model of the fastest growing alternative energy sources in the world; wind turbines efficiently convert the energy of the wind into electricity with minimal impact on the environment. Over 15" in height, each operating turbine rotates at a realistic, constant speed. Accurately modeled details include spinning blades, "nacelle" housing, vertical tower, and base with tower entrance.

- Realistic rotation of turbine blades
- Constant rotating speed
- Height: 15½"

6-22583 **\$74.99**

I. BIODIESEL STORAGE TANK

Another innovation in energy conservation. Biodiesel advocates say that it saves three and one quarter units of energy for every unit of fossil fuel used to manufacture it.

- Two figures included
- Dimensions: Approx. 10½" x 4"

6-22577 **\$39.99**

J. BOLLARDS & CHAINS PACK

Use the bollards alone to stop vehicles or thread the chain through to create a continuous barrier.

- Includes 8 Bollards & 16 small clips and two 12" Chains
- Height: 11/8"

6-22580 **\$19.99**

H

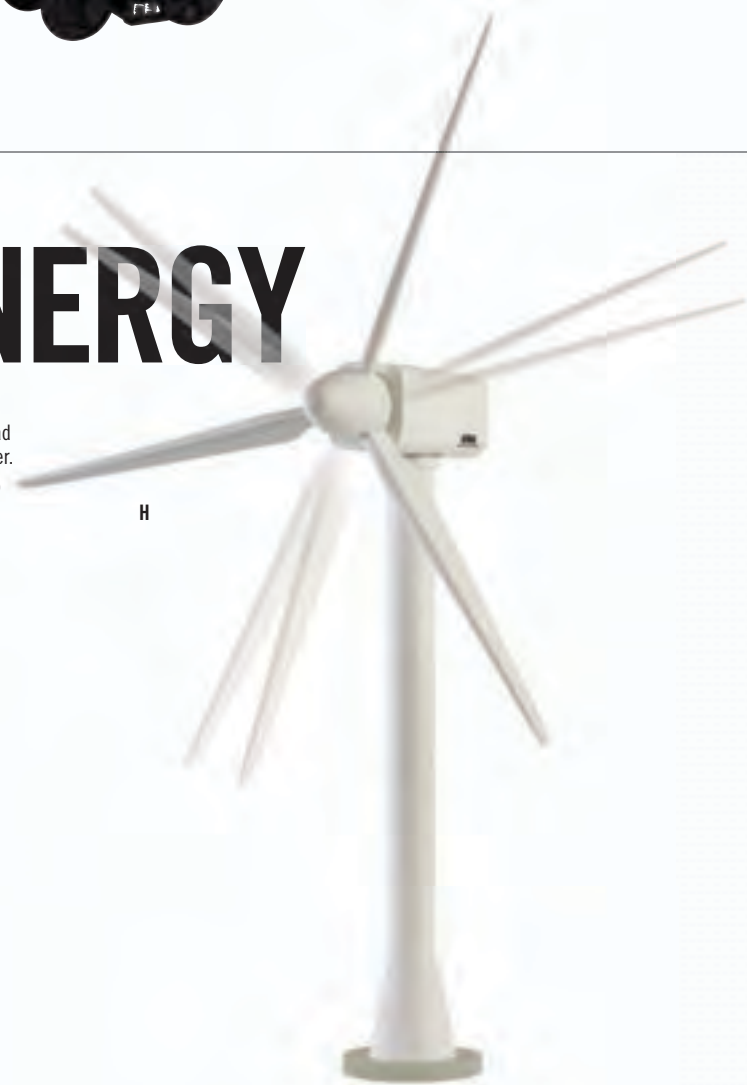



BOX CARS AND REEFERS

- Fully-sprung die-cast trucks
- Operating die-cast couplers
- Metal chassis
- Minimum Curve: 0-27

- C. 6-21633 Rock Island Route of Rockets Boxcar \$44.99
- D. 6-21627 Greenlee Packing Co Wood-Sided Reefer \$44.99
- E. 6-22640 Central of Georgia Boxcar \$44.99
- F. 6-22662 Pennsylvania Reefer \$44.99
- G. 6-22641 New Haven Boxcar \$44.99



OPERATING ACCESSORIES

Innovative and Exciting Action

A. OPERATING FLAGMAN'S SHANTY

Place this accessory next to the track. When the train goes by, the flagman emerges with his lantern. The lantern illuminates as he stands in position. After the train passes, the flagman turns completely around and goes back into the shanty.

- Train activated operation
- Smooth trackless motion
- Detailed figure
- Illuminated shanty and lantern
- Dimensions: Approximately 8½" x 5½"

6-22658 \$99.99

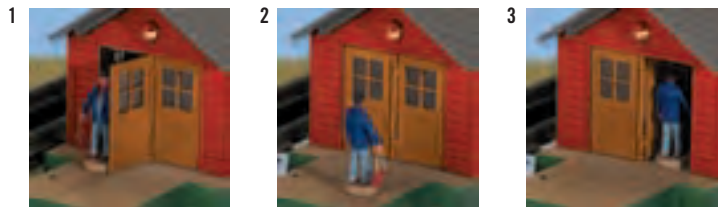

A

B. ROADSIDE FENDER BENDER

Fasten Your Seat Belt! At least, let's hope so. The driver lost control but it seems like most of the damage is to the fence. Although with all that smoke he might want to check under the hood.

- Smoke unit with On/Off switch
- Realistic smoking action
- Die cast vehicle included
- Dimensions: Approximately 9½" x 6¾"

6-22590 \$74.99



B

C-E. THE BEST MILK CAR FREIGHT CYCLE

The milk depot automatically loads the milk cans through the side-door into the waiting reefer – no manual loading through the roof hatch. Milk cans are transported inside the car and unloaded out the opposite side to the platform anywhere on the layout. All done with a smooth-operating motor.

C. CENTRAL VERMONT OPERATING MILK CAR AND UNLOADING PLATFORM

- Die-cast sprung trucks
- Die-cast operating couplers
- Unloads with any USC Track or 6-21438 Remote Control
- 6 milk cans
- Dimensions: Platform 6½" x 3¾"

6-22651 \$174.99

D. MILK CAN SET

- 10 cans

6-22325 \$9.99

E. MOOSE POND CREAMERY OPERATING LOADING DEPOT

- Adjustable height for variety of tracks
- Push button activation
- 6 milk cans
- Dimensions: 12½" x 3½"

6-22660 \$139.99



NEW



C



D

NEW



E

F

ACCESSORIES

More Action, Sound, Light and Realistic Details

A. NEW YORK CENTRAL GIRDER BRIDGE

6-22514 \$14.99

B. OLD READING FLATCAR FOOT BRIDGE ON STONE PIERS

An old flat cars has been recycled as a walkway, hiking and biking bridge. Install one on your layout with or without the stone piers.

- Detailed resin casting

6-22587 \$49.99

C. THE STARLITE DINER WITH PARKING LOT

Rock 'n Roll from the juke box, the aroma from the kitchen and we are in one of our favorite places – a classic American diner.

- Operating smoke unit with On/Off switch
- Lighted interior with figures
- Lighted roof sign
- 50s jukebox sounds
- Parking lot with painted stripes
- Dimensions: Approximately 15 ¼" x 8 ¼"

6-22653 \$199.99

D. DUAL TRACK SIGNAL BRIDGE

- New LED signals
- Lights change from red to green as train passes

6-22329 \$44.99

E. ACME SCRAP PLATFORM CRANE

Mounted on a sturdy base of beams and footers, the fully detailed crane features a boom that can be moved up or down, while crane body can rotate a full 360°. The metal hook can be raised and lowered to load and unload freight.

- Manual operation with two controls to raise and lower boom and hook
- Full 360° rotation
- Dimensions: Base 3¾" x 3¾"

6-22667 \$59.99

F. STONE-STYLE BRIDGE PIERS

Two piers – perfect for girder bridge

- Detailed resin casting
- Height: 6"

6-22363 \$29.99

G, H. TUNNEL PORTALS

- Detailed resin casting

G. 6-21396 Single Tunnel Portals \$19.99

H. 6-21454 Double Tunnel Portals \$24.99

I. MAIL CRANE

Our non-operating mail crane is a detailed, scale replica that looks perfect trackside.

- Removable bag
- Dimensions: Base 2½" x ½" Height 3½"

6-22438 \$29.99

J. TWIN SEARCHLIGHT TOWER

- High-intensity illumination
- Dimensions: Base 4½" x 4½"

6-22326 \$34.99

K. AIRPORT REVOLVING SEARCHLIGHT

- Rotating green beacon rotates
- Dimensions: Base 4½" x 4½"

6-22492 \$39.99

L. LOADING RAMP

Just right for any siding.

- Detailed resin casting
- Dimensions: 9¾" x 3"

6-22202 \$19.99



Figures not included



NEW





E

NEW



F



G
H



I



J

NEW



K



L

REAL ESTATE DEVELOPMENT IS A SNAP

Snap-together buildings are ready to assemble

A. 6-21386 Firehouse \$17.99

• Dimensions 8¼" x 4½"

B. 6-21387 Church \$17.99

• Dimensions 3¾" x 6¾"

C. 6-21381 Suburban Station \$18.99

• Dimensions 12" (includes steps) x 5¼"

D. 6-21385 Barn & Chicken Coop \$22.99

• Barn Dimensions 4¼" x 6"

• Silo Diameter 1¾"

• Coop Dimensions 7½" x 3 ¾"

E. 6-21378 Factory \$22.99

• Dimensions 7¼" x 10¾"

F. 6-21389 Supermarket \$15.99

• Dimensions 8¼" x 3¾"

G. 6-21380 Colonial House \$19.99

• Dimensions 11½" x 4¼"

H. 6-21384 Service Station with Gas Pumps \$19.99

• Dimensions 8" (excludes pumps) x 4½"

I. 6-21388 Country L-Shaped Ranch House \$17.99

• Dimensions 10" x 6½" (includes "L")

J. 6-21379 Police Station \$19.99

• Dimensions 6" x 4¾"

K. 6-21383 Suburban Ranch House \$15.99

• Dimensions 9" x 3½"

L. 6-21382 School \$19.99

• Dimensions 9¾" x 5¾"

M. 6-21390 Diner \$17.99

• Dimensions 9¾" x 4"

N. 6-22553 Convenience Mart \$24.99

• Dimensions 9½" x 5¾" (with roof overhang)

O. 6-22554 City Auto Parts Store \$19.99

• Dimensions 8¼" x 4"

A



B



C



D

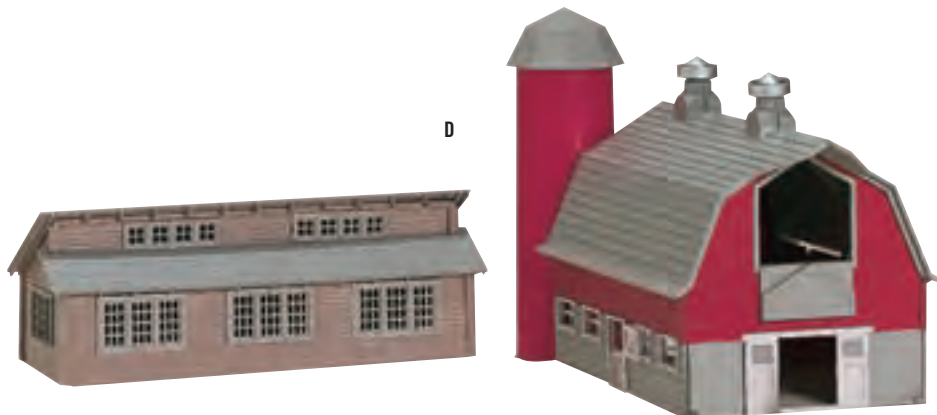

E





F



G



H



I



J



K



L



M



N

O



N



O



P



Q

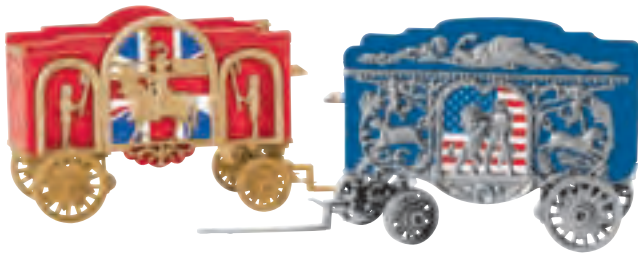

R

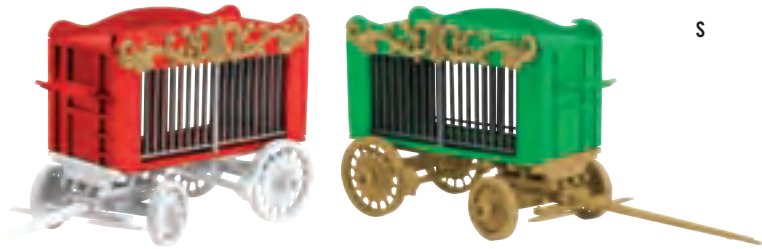

S

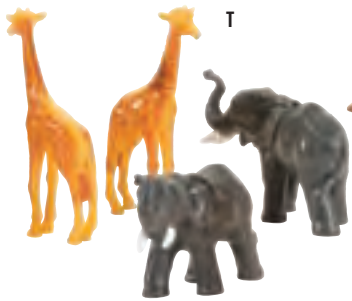

T



U



V

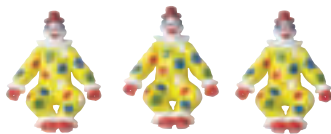

X



W



Y



AMERICAN FLYER

A. 959 DEFENDER SET

Here it is! The set you have always wanted, beautifully recreated. From the sleek little bell ringer C & O GP-7 to the Rocket Launcher and Searchlight Cars, this set has all the makings of childhood memories with the features you've come to expect. Roll down the rails with this set and keep your railroad empire safe from intruders with 'The Defender'. First cataloged in 1959, this American Flyer favorite has been brought back for everyone to enjoy today!

Similar to the original, the set includes

GP-7 diesel with ringing bell, Navy flatcar with vehicles, searchlight car, Marines boxcar, rocket launcher, and caboose

Locomotive Features

- Transformer controlled forward, neutral, and reverse operation
- Powerful maintenance-free motor
- Ringing bell
- Directional lighting, including operating headlight and back-up light
- Interior cab light
- Front and rear operating couplers
- Traction tires
- Metal frame
- Die-cast metal trucks
- Length: 7 1/8"

Rolling Stock Features

- Die-cast metal trucks with operating couplers
- Illuminated searchlight on searchlight car
- Removable vehicles on Navy flatcar
- Removable rocket on rocket launcher car
- Metal frame and opening doors with latches on boxcar
- Interior illumination in caboose
- Set length: Approx. 48"

6-49624 \$599.99

B. 1959 CATALOG ART BOXCAR

- Die-cast metal trucks and operating couplers
- Metal frame
- Opening doors with operating latches
- Length: 8 3/4"

6-48385 \$69.99



ALL ITEMS
NEW

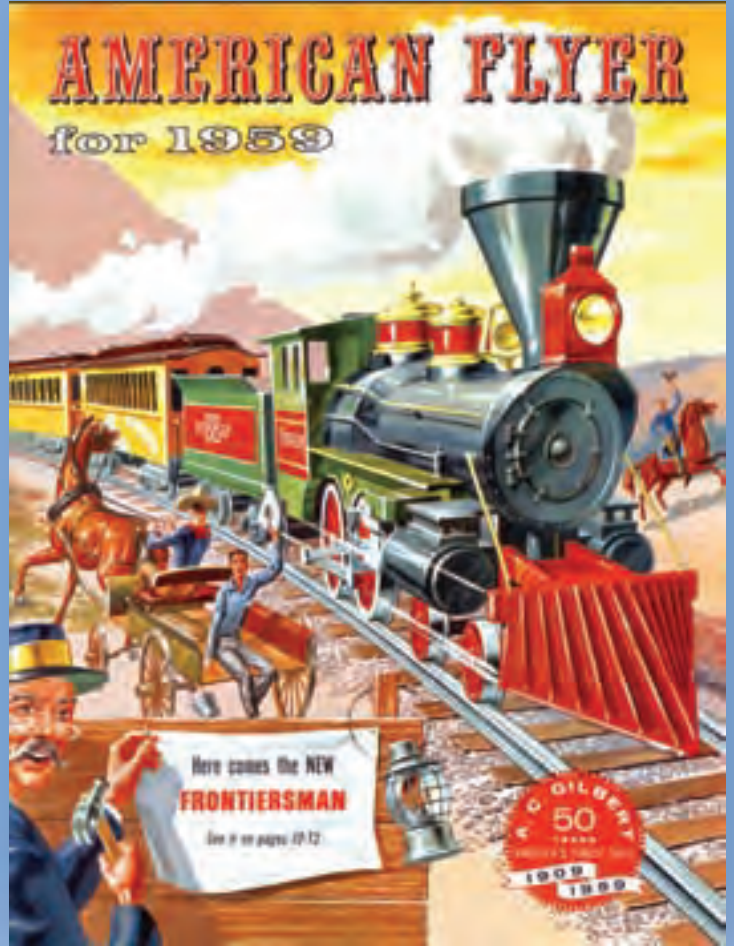

1959



“The Defender”

America's Train of Tomorrow!



RIO GRANDE

A. RIO GRANDE ALCO PA A-A SET

Set Includes

One PA powered unit and one PA non-powered unit

Powered Unit Features

Transformer controlled forward, neutral, and reverse operation

- Die-cast metal trucks and operating couplers
- Directional lighting, including operating headlight and back-up light
- Metal frame
- Dual powerful maintenance free motors
- Traction tires

Non-Powered Unit Features

- Die-cast metal trucks and operating couplers
- Metal frame
- Operating headlight
- Diesel horn sound

Length of single PA: 13"

6-48155 \$369.99

B. RIO GRANDE STREAMLINER PASSENGER CAR 3-PACK

3-Pack Includes

- Coach, vista dome, and observation car
- Die-cast metal trucks and operating couplers
- Metal frame
- Window silhouettes
- Interior illumination
- Length: 13 3/8"

6-49936 \$249.99

C. RIO GRANDE GIRDER BRIDGE

- Stamped metal base
- Plastic girder sides
- Designed to fit S gauge track
- Length: 10"

6-49850 \$20.99

D. RIO GRANDE STREAMLINER BAGGAGE CAR

A great add-on car for your next Rio Grande excursion!

- Stamped metal frame
- Die-cast metal trucks and operating couplers
- Window shade silhouettes
- Interior illumination
- Length: 13 3/8"

6-49945 \$79.99



A



B



NEW



D



NEW



WESTERN PACIFIC 2-8-2 LEGACY MIKADO

A. 2-8-2 LEGACY MIKADO

Add this popular western road name to your livery and watch as the Mikado takes to the rails right into American Flyer history! One of the first A/F locos to be equipped with the revolutionary Lionel LEGACY Control System, this beautiful scale locomotive has loads of features and all the bragging rights you deserve. Complete with incredible details and the features that would make even A.C. Gilbert himself proud.

- **LEGACY Control System** equipped – able to run in LEGACY Control Mode, in TrainMaster Command Control Mode, or in Conventional Mode with a standard transformer
- **LEGACY RailSounds** sound system featuring
 - CrewTalk dialog and TowerCom announcements, each with different scenarios depending on whether the locomotive is in motion or stopped
 - DynaChuff synchronized chuffing
 - LEGACY “Real-Time Quilling Whistle” control with instant response for realistic ‘quilling’ and correctly timed warning signals

- Single hit or continuous bell sounds
 - Realistic operator-controlled effects
 - Independently adjustable volume control
 - **Wireless Tether** connection between locomotive and tender
 - Four chuffs per revolution
 - Powerful motor with momentum flywheel
 - **ElectroCoupler** on rear of tender (new feature on American Flyer locos)
 - Directional lighting including operating headlight, classification lights and operating back-up light on the tender
 - Illuminated cab interior
 - Die-cast metal locomotive body, frame, pilot and trucks
 - Die-cast metal tender body and trucks
 - Traction tires
 - Separately applied metal details
 - Engineer and fireman figures
 - Length: 15 ½”
- 6-48081 \$699.99**

B. WESTERN PACIFIC BOXCAR

- Die-cast metal trucks and operating couplers
 - Metal frame
 - Opening doors with operating latches
 - Length: 8 3/8”
- 6-48388 \$69.99**

C. WESTERN PACIFIC BAY WINDOW CABOOSE

- Die-cast metal trucks and operating couplers
 - Metal frame
 - Interior lighting
 - Length: 7”
- 6-48754 \$69.99**

A



B



C



ROLLING STOCK

A. NEW YORK CENTRAL PACEMAKER STOCKCAR

- Die-cast metal trucks and operating couplers
- Metal frame
- Opening doors with operating latches
- Length: 8 3/8"

6-48386 \$69.99

B. AIRCO BOXCAR

- Die-cast metal trucks and operating couplers
- Metal frame
- Opening doors with operating latches
- Length: 8 3/8"

6-48387 \$69.99

C. JERSEY CENTRAL FLATCAR WITH BOAT LOAD

- Die-cast metal trucks and operating couplers
- Metal frame
- Removable boat load
- Length: 8 3/8"

6-48561 \$69.99

D. BAKELITE FREIGHT CAR 2-PACK

2-Pack Includes

Three dome tank car, covered hopper

Features

- Die-cast metal trucks and operating couplers
- Metal handrails and ladders on tank car
- Length: tank car 7 3/8"
hopper 7 3/8"

6-49625 \$134.99



C



ALL ITEMS
NEW

D



D



2-PACK

ROLLING STOCK

A. DM & IR SINGLE DOME TANK CAR

- Die-cast metal trucks and operating couplers
- Metal handrails
- Length: 7 5/8"

6-48428 \$69.99



B. SANTA'S CANDY SHOP HOPPER

- Die-cast metal trucks and operating couplers
- Removable cover
- Length: 8 3/4"

6-48632 \$69.99



C. D. SINGLE DOME TANK CARS

- Die-cast metal trucks and operating couplers
- Metal handrails and ladders
- Dome deck
- Length: 7 5/8"

C. 6-48430 Comet® \$69.99 t

D. 6-48431 Sunoco® \$69.99

Comet® is a registered trademark of Prestige Brands.
SUNOCO® is a registered trademark of Sunoco, Inc. and its subsidiaries.



D



E. CIRCUS STOCK CAR

- Die-cast metal trucks and operating couplers
- Metal frame
- Opening doors
- Length: 8 3/4"

6-48380 \$69.99

F. POST OFFICE BOXCAR

- Die-cast metal trucks and operating couplers
- Metal frame
- Opening doors
- Length: 8 3/4"

6-48383 \$69.99

G. UNION PACIFIC HOPPER

- Die-cast metal trucks and operating couplers
- Removable coal load
- Length: 7 3/4"

6-48633 \$69.99

H. BNSF FLATCAR WITH JET ENGINE LOAD

- Die-cast metal trucks and operating couplers
- Metal frame
- Two removable jet engine loads
- Length: 8 3/4"

6-48560 \$69.99



E

F

G



H

OPERATING ACCESSORIES



GN deco on tray top

A. GREAT NORTHERN LOG DUMP CAR

- Die-cast metal trucks and operating couplers
- Includes operating contactor, dumping bin and four wooden logs
- GN decoration on tray top
- Length: 7 1/8"

6-49054 \$79.99

B. WABASH COAL DUMP CAR

- Die-cast metal trucks and operating couplers
- Includes operating contactor, dumping bin and coal load
- Length: 7 1/8"

6-49055 \$89.99

C. COMMEMORATIVE UNLOADING CAR

- Die-cast metal trucks and operating couplers
- Metal frame and ramp
- Removable gasoline car
- Special A/F commemorative paint scheme
- Includes contactor and activation button
- Length: 9"

6-49049 \$84.99





B



C

PASSENGER CARS

The excitement continues with these new American Flyer cars. They feature a realistic and distinctive “bi-level” window configuration on one side of the car and single level configuration on the opposite side. The full vista dome car will look great and turn heads as it makes its way down the rails in your existing passenger set

A-C. STREAMLINER FULL VISTA DOME CARS.

- Die-cast metal trucks and operating couplers
- Stamped metal frame
- Window silhouettes
- Interior illumination
- Unique window configuration on each side of car
- Length: 13 1/8"

A. 6-49940 Santa Fe \$79.99

B. 6-49941 Union Pacific \$79.99

C. 6-49942 New York Central \$79.99

STREAMLINER BAGGAGE CARS

- Stamped metal frame
- Die-cast trucks and operating couplers
- Window shade silhouettes
- Interior illumination
- Length: 13 1/8"

D. 6-49934 Chesapeake and Ohio \$79.99

E. 6-49935 Northern Pacific \$79.99





C



D



E



ACCESSORIES

A. #774 FLOODLIGHT TOWER

- Metal platform, ladder and lamp sockets
- Four operating lights
- Dimensions: 5" x 6" x 13"

6-49847 \$119.99

B. #773 SUNOCO® OIL DERRICK

A favorite American Flyer accessory now in the brilliant colors of Sunoco®

- Illuminated bubble tube
- Dimensions: 4 7/8" X 4 7/8" x 12 5/8"

6-49846 \$79.99

SUNOCO® is a registered trademark of Sunoco, Inc. and its subsidiaries.

SUBURBAN STATION

- Interior illumination
- Frosted windows
- Dimensions: 10" x 7 1/4" x 4 3/4"

6-49843 \$69.99

D. #793 UNION STATION

This big-city station, with its impressive front entrance and tower, is all ready to handle the rush of commuter and out-of-town traffic on your railroad system. Because the tower unit is movable, the station can be set up in a variety of ways. Use as shown, or have the entrance at the station end. It is a perfect companion piece to #792 Railroad Terminal.

- 18 frosted windows
- Metal roof
- Die-cast metal ventilators on roof
- Movable tower with doors and clock
- Step unit
- Removable American Flyer flag on tower roof
- Interior illumination
- Dimensions: 16" L, 6 3/4" H, 11" W

6-49839 \$89.99

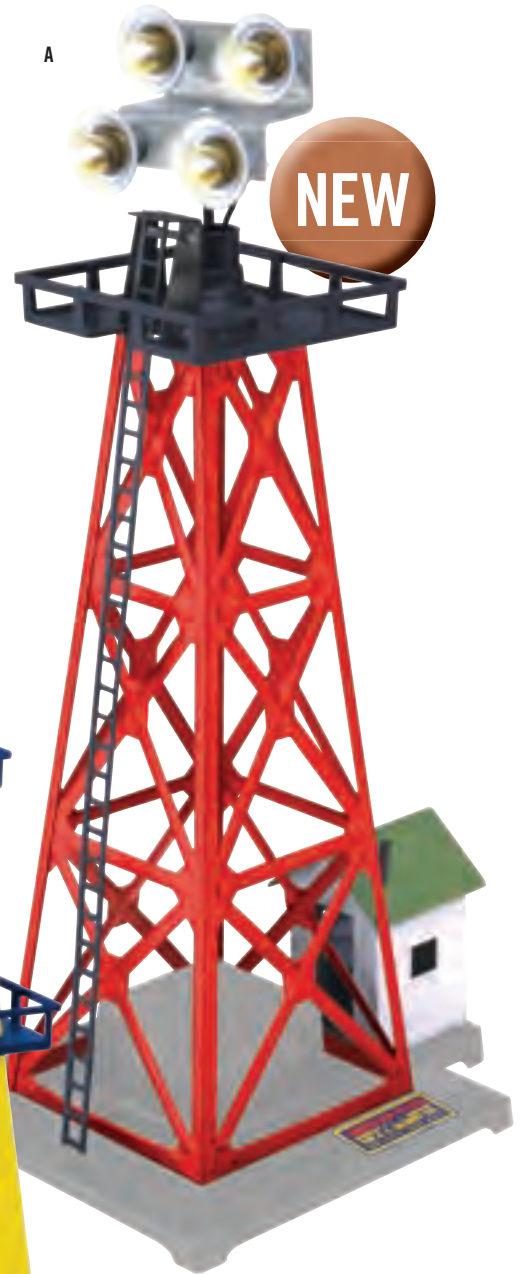

AMERICAN FLYER S GAUGE TRACK

E. STRAIGHT TRACK

Length: 10"

6-49828 \$3.99

F. CURVED TRACK

(12 pieces per 54" diameter circle)

6-49827 \$3.99

G. STRAIGHT TRACK

Length: 36"

6-49829 \$10.99

H. UNIVERSAL LOCKON

Works with O/O-27 and S

6-24213 \$3.99

STEEL PINS (NOT SHOWN)

6-49831 S Gauge \$2.19

FIBRE PINS (NOT SHOWN)

6-49830 S Gauge \$2.19

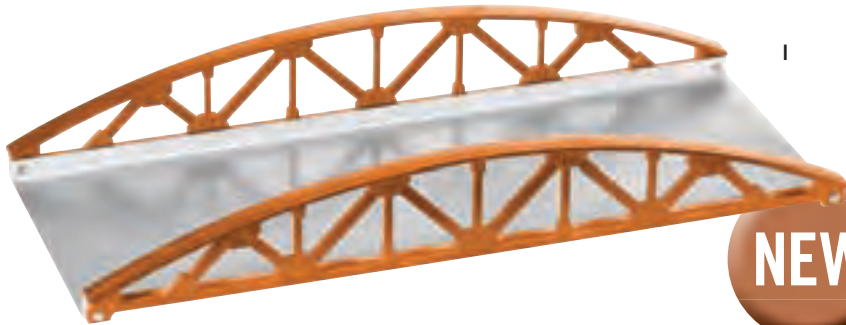
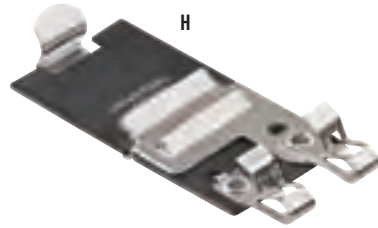

NEW

I. TRUSS BRIDGE

- Stamped metal base
- Plastic truss girder sides
- Length: 10 3/4"
- Width: 4 3/4"

6-49845 \$26.99



NEW

GIRDER BRIDGE

Based on the popular O gauge version, these girder bridges are adapted for S gauge and done in familiar American Flyer road names.

- Stamped metal base
- Plastic girder sides
- Designed to fit S gauge track
- Length: 10"

J. 6-49849 Lackawanna \$20.99

K. 6-49848 American Flyer Lines \$20.99



NEW

LARGE SCALE TRACK
(Not Shown)

LARGE SCALE TRACK (NOT SHOWN)

STRAIGHT TRACK

Length: 11 3/4"

8-82000 \$6.39

CURVED TRACK

Length: 13" (12 pieces make a 4.3-foot diameter circle)

8-82001 \$6.39

WIDE RADIUS CURVED TRACK

Length: 16" (12 pieces make a 5.3-foot diameter circle)

8-82004 \$6.39

LOCKON WITH WIRES

Designed for quick, positive connections between transformers, track, and accessories

8-82101 \$8.69

UPGRADES BY ELECTRIC RR

The Electric RR Co. specializes in command control compatible product design. For more information on these and other Electric RR products, or product installation questions, please call 408-454-4127, or visit www.electricrr.com.

A. SOUND COMMANDER 2™

With Sound Commander 2, you get a low cost way to add sound to your locomotives. The Sound Commander 2 has extended conventional mode functionality, including two volume selections. With its small, compact size, it can be installed into many Modern era and Post war locomotives, yet delivers over 1 watt of output power. This sound upgrade kit can operate in conventional mode with horn / bell buttons, or in command mode when interfaced to compliant products.

Sound Commander 2 kit includes

- “Low profile” 2 inch diameter speaker speaker baffle, mounting supplies, comprehensive installation manual, and connection cables for conventional and command operation.

Features

- Conventional and Command mode operation
- Command mode volume control from the CAB-1, 4 levels and mute
- Conventional mode volume control with jumper or switch
- Custom sound processor for field upgrades or enhancements
- Direct connection to the entire Electric Railroad product line
- Dimensions: 1.5” L x 1.25” W x 0.75” H

Additional Diesel Features

- Prime Mover revs with 4 speed levels, 4 volume levels and mute
- Volume of Prime Mover and Warning Sounds individually settable
- Monitors 32/100 speed step selections to adjust rev level appropriately
- Choose one of the following diesel sound sets: GP7/GP9, ALCo, RDC, F3/F7, GG-1, NW-2

Additional Steamer Features

- Steam Idle sounds with Brake Compressor sounds
- Chuff cadence (4 unique chuffs) triggered from external chuff switch
- Volume of Chuff and Warning Sounds individually settable
- Blow Off sound, controlled from the CAB-1
- Choose one of the following steam sound sets: Atlantic, Pennsylvania, Switcher

Command & Conventional Mode Sounds

- Horn / Whistle
- Bell (diesel or steam)
- Coupler Clank (activated by Bell button in conventional mode)
- Air Release (activated by Bell button in conventional mode)
- Diesel - Prime Mover revs
- Steamer - Idle steam, compressor pump

Diesel Sound Commander 2 \$49.95

Steam Sound Commander 2 \$54.95

B. CRUISE COMMANDER™ “M”

For Modular TMCC locomotives, upgrade your speed control with Cruise Commander “M”. Imagine how many locos without flywheels that can now have cruise functionality! The Cruise Commander “M” replaces the Lionel modular motor driver. It is plug compatible, and a minimal install only requires the addition of a single wire to the serial data for operation.

- Simple Tach-Less installation and operation
- High Frequency (20khz) PWM for silent drive
- Operates in command and conventional modes
- CAB-1 selectable 32 or 100 (default) speed steps
- Serial data out for configuration acknowledgment
- Directly drives LED's lighting without complex “load” resistor wiring
- LED's lighting features include markers and oscillating ditch lamps
- On-board micro-controller provides future enhancement capabilities
- Dimensions 2.4” L x 1.63” W x 0.8” H

Cruise Commander M \$89.95

C. CRUISE COMMANDER™

Take command of locomotive speed with Cruise Commander, a patented breakthrough in speed control technology. The Cruise Commander provides constant speed and ultra-slow operation of your locomotives, and it's simple to install. While in operation, information about your locomotive's velocity is monitored from the motor directly. If dual-motored, each motor is balanced to the other, synchronizing the motors for smooth and quiet operation. Lash-ups are also possible when locomotives are aligned using the exclusive “nudge” feature.

- Simple Tach-Less installation and operation
- High Frequency (20khz) PWM for silent motor operation
- Operates in command and conventional modes
- CAB-1 selectable 32 or 100 (default) speed steps
- Uses R2LC to be fully compliant with TMCC standards
- Horn pulse to control modern-era and post war horns / whistles
- Directly drives LED's lighting without complex “load” resistor wiring
- On-board micro-controller provides future enhancement capabilities
- Splice-free connections make installation simple and quick
- Heat Sink has “PemNut”, no more stripped mounting holes!
- Dimensions: 2.75” L x 1.25” W x 1.2” H

Cruise Commander \$119.95

D. RAILSOUNDS COMMANDER™

Upgrade your locomotives to RailSounds 4.0 with the RailSounds Commander. At a compact size unparalleled in the marketplace, almost all your locomotives can now feature a realistic, high performance sound system! Fully compliant with TMCC standards, RailSounds Commander utilizes Lionel RS4 technology, combining it with a single power controller that supports conventional mode including battery backup. The RailSounds Commander operates standalone, or in conjunction with the full product line of Electric Railroad's TMCC upgrades.

Railsounds Commander Kit Includes

High performance speaker, speaker baffle, mounting supplies, comprehensive installation manual, and connection cables for conventional and command operation.

Features

- Conventional and Command mode operation
- Command mode volume control
- On-board volume control for conventional operation
- Multiple trigger options for chuff and diesel ramp up/down
- Provisions for a Railsounds/Signal Sounds switch
- On-board volume control for conventional operation
- Battery (9v) supports convention mode operation
- Easily interfaces with entire Electric Railroad Company line of products
- Fully compliant with TMCC standards
- Dimensions: 1.95” L x 1.25” W x 0.95” H
- Diesel Sound Sets: ALco, F3/F7, E8/9, Geep 7/9, Dash 9
- Steam Sound Sets: Atlantic, Northern, Generic, Articulated

RailSounds Commander \$99.95

A



B



C

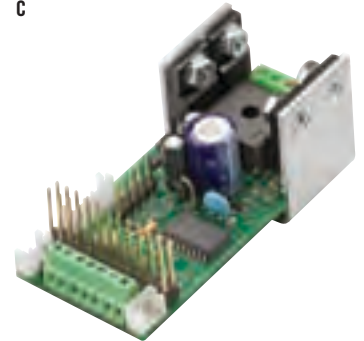

D





For more than 30 years, the Lionel RailRoader Club has provided it's members with exclusive Lionel news, special promotions, merchandise discounts and Lionel catalogs. This is your opportunity to join thousands of others in this legendary club.

TO JOIN THE LIONEL RAILROAD CLUB:

Write to: Lionel RailRoader Club
 26750 Twenty-Three Mile Road, Chesterfield, MI 48051-1956, USA
 Call (586) 949-4100 or visit www.lionel.com

Your membership includes these great club benefits for a whole year!

- Quarterly issues of Inside Track featuring Lionel news, special promotions, and opportunities to purchase exclusive LRRC cars.
- Lionel Catalogs delivered to you right off the press, arriving just after our dealers receive them!
- Collectible, annual Club Button and LRRC Membership Card.



